

1. Introduction

This application note serves as a primer for designing with the Clare, Inc. LITELINK II Silicon Data Access Arrangement (DAA). LITELINK II circuit functions are described in the context of the external components required to complete a telephone line interface system.

See the LITELINK [data sheets and application notes](#) for more information. Also see the references cited in this application note for a more complete understanding of public switched telephone network (PSTN) connectivity and designing with the LITELINK II.

1.1 Telephone Network Connection

Devices that connect to the PSTN require a data access arrangement circuit (DAA). The DAA provides the physical connection between the telephone line and the device, while, at the same time, providing the necessary electrical isolation that is required by regulatory agencies such as the FCC. Examples of some common devices are modems, set-top boxes, point-of-sale terminals, answering machines, vending equipment, and metering equipment.

Isolation of host equipment from the PSTN assures that no harm to the PSTN occurs due to a device malfunction in the customer premises equipment (CPE). Without isolation, a device connected to the PSTN could damage central office equipment and endanger telephone company personnel if it failed. Additionally, if a high voltage transient is applied to the telephone line from an outside source (a lightning induced transient, for example), the device and user are generally protected from this event due to the high electrical isolation that a DAA provides.

1.2 DAA Functions

In addition to the primary function of isolation, a DAA circuit must also provide the following functions while meeting stringent regulatory requirements:

1. Line termination
2. 2-to-4 wire conversion (hybrid function)
3. Ring detection
4. Signal coupling
5. Monitoring on-hook transmissions (snoop)
6. Surge/transient protection

Figure 1. DAA Block Diagram

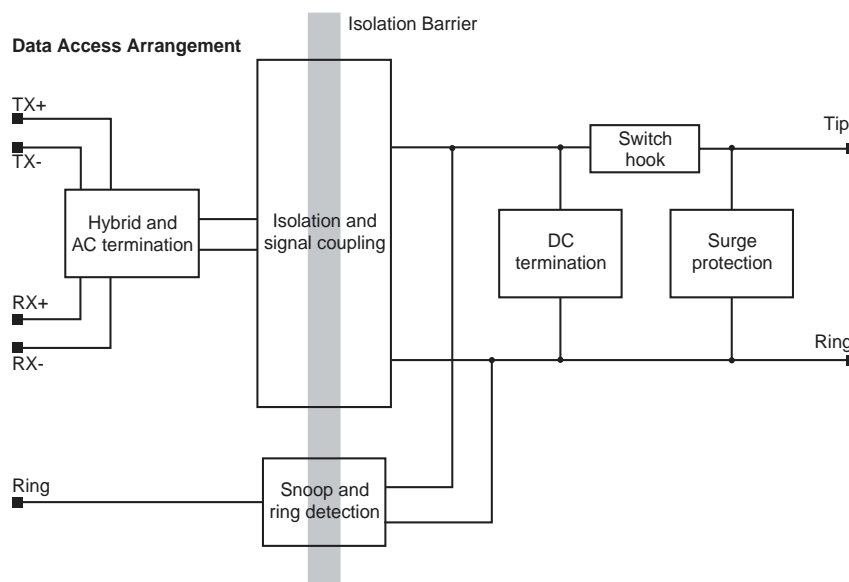

2. DAA Architecture

The block diagram (see Figure 1 on page 1) shows the relationship of DAA components. The telephone line connection to many devices, such as modems, is made via an RJ-11 jack. The two center terminals of the jack are normally used and connected to the inner pair of the telephone lines designated tip and ring.

2.1 Surge Protection

The surge protection block protects the CPE from damage, most likely lightning induced transients or power-cross events. Protection circuit topology varies and is determined by the system's reliability criteria.

2.2 Switchhook

The switchhook controls the off-hook and on-hook conditions. When the switchhook is closed, the device is off-hook and current flows from the central office battery through the switchhook and DC termination circuit. This current is known as the loop current. The magnitude of the loop current is usually between 20 mA and 120 mA depending on loop length. The tip lead is positive with respect to the ring lead with a nominal voltage of 48 Vdc open circuit (on-hook). When the switchhook is open, the DAA is on-hook and current draw must be less than 20 μ A with 100 Vdc applied across tip and ring.

2.3 DC Termination

The DC termination presents a low DC resistance across tip and ring when the DAA is off-hook, but maintains a very high AC impedance that will not interfere with the 600 Ω AC termination of the DAA. The DC termination also has a bridge rectifier that allows the circuit to operate even if the tip and ring leads are inadvertently reversed.

2.4 Ring Detection

The ring detection block connects across the tip and ring terminals and is used to monitor the line for an incoming ring signal. The circuit is AC coupled in order to meet the on-hook current draw criteria. The ring detection circuit requires an isolation barrier to isolate the telephone line from the CPE power supply. The ring signal from the CO is usually a 20 Hertz AC sinusoid with a voltage of between 40 V_{RMS} and 90 V_{RMS} .

The output of the ring detect circuit is a TTL output signal that is microprocessor compatible.

2.5 Isolation and Signal Coupling

The isolation and signal coupling block couples the AC signal to and from the host system while maintaining linearity and providing electrical isolation in excess of 1500 V_{RMS} . The most common component used for this application has historically been a transformer.

2.6 Hybrid

The hybrid network is also known as the 2-to-4 wire converter. Since both transmit and receive signals are on the same telephone line pair at the same time (full duplex), a mechanism is required such that the transmitted signal from the device is removed or minimized at the device receive path. For data applications, poor rejection of the transmit signal in the receive path can cause poor data throughput. The loss from transmit path to receive path is known as trans-hybrid loss, measured in decibels.

3. LITELINK™ II DAA

Clare's LITELINK II DAAs (CPC5610 and CPC5611) provide the functions described above with minimal external components. The LITELINK II DAA is based on optical isolation and signal coupling techniques in order to maintain a high degree of signal integrity and the required high-voltage isolation. The LITELINK II

DAA is a multi-chip device in a 32-lead SOIC package. One of the advantages of using the multi-chip approach is that the chip on the telephone-line side of the IC is galvanically isolated from the chip on the CPE side of the IC, providing an effective means of isolation inside the package.

4. LITELINK II DAA Circuit Blocks

The block diagram in Figure 2 shows the circuits that make up the LITELINK II DAA. Use this figure to see the interaction of the circuits described below.

Figure 2. LITELINK II DAA Block Diagram

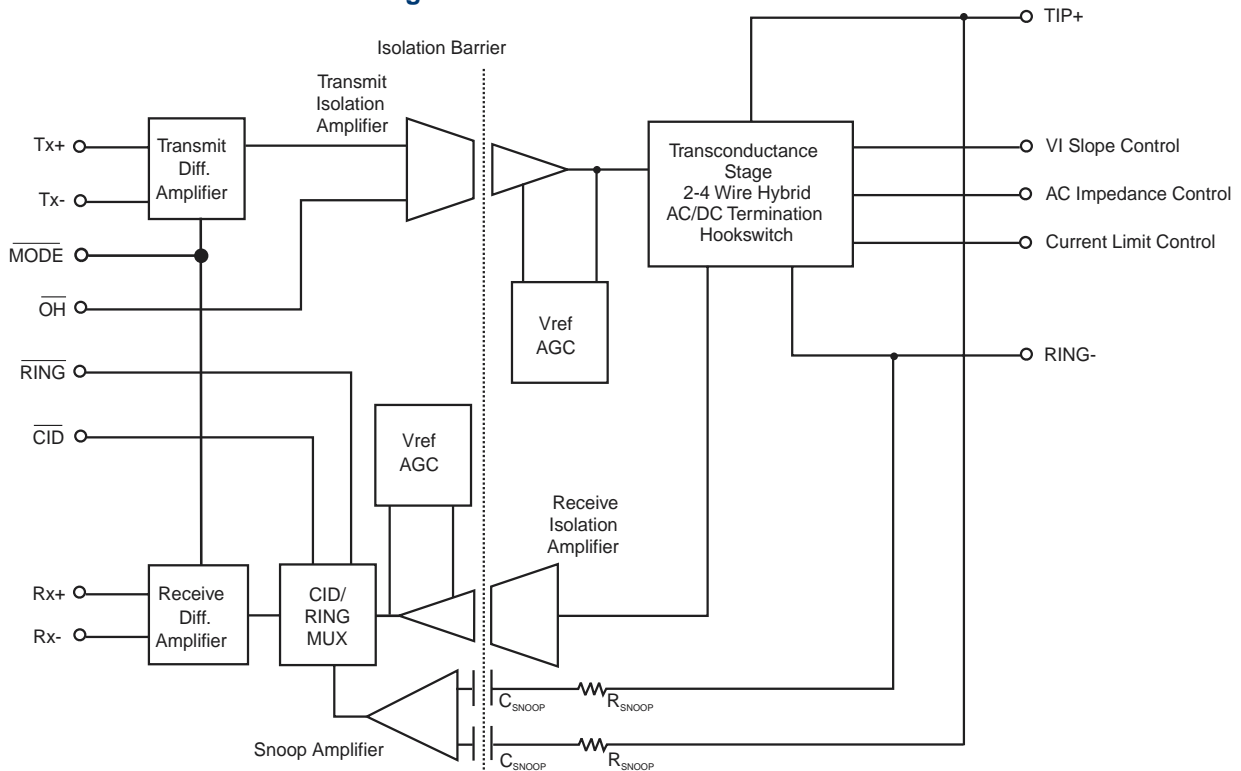

4.1 On-hook Operation

4.1.1 Ring Signal Detection

Figure 3. Ring Signal Detection Circuit

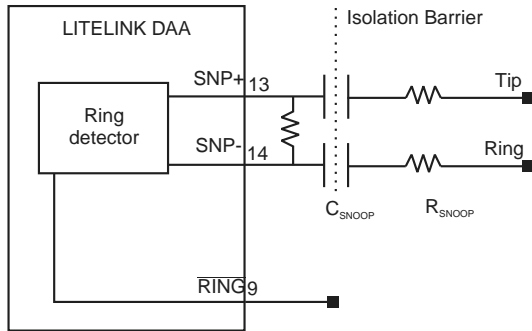

With $\overline{\text{OH}}$ and $\overline{\text{CID}}$ de-asserted (floating or logic high) the LITELINK II DAA detects ring signals as shown in Figure 3. The snoop network consists of a balanced pair of R_{SNOOP} and C_{SNOOP} connected in series with tip and ring. Note that the dotted line bisecting the snoop capacitors indicates the high-voltage isolation barrier between the telephone line and CPE device. The impedance of the C_{SNOOP} and R_{SNOOP} network is very high, making a suitable interface for the CMOS LITELINK II DAA. The detected ring output is presented as a microprocessor compatible signal. Note that the ring detect circuit is powered by the CPE power supply and requires no telephone line power to operate. See the Clare, Inc. application note AN-117 [Customize Caller-ID Gain and Ring Detect Voltage Threshold for CPC5610/11](#) for more details.

The following table lists the signal paths and functions for the possible states of the $\overline{\text{CID}}$ and $\overline{\text{OH}}$ control lines.

$\overline{\text{CID}}$	$\overline{\text{OH}}$	Path and Function
X	0	LITELINK II DAA is off-hook. Receive signals are routed through photodiode amplifier to RX+ and RX-. $\overline{\text{RING}}$ output forced inactive (logic high).
0	1	Output of snoop amplifier connected to RX+ and RX-. $\overline{\text{RING}}$ output forced inactive (logic high). This is the caller ID detection state. Enable after the first ring.
1	1	DAA on-hook. Snoop amplifier disconnected. Ring detector enabled.

4.1.2 Ring Signal Processing

Figure 4. Ring Signal Waveforms

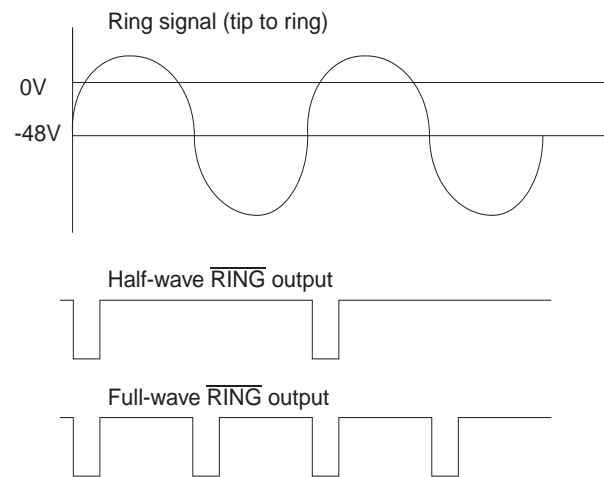

Since the ring detect circuit in the LITELINK II DAA is AC coupled, the DC component doesn't affect the detection threshold (see Figure 4). The figure shows the output waveforms for both the full- and half-wave versions of the LITELINK II DAA. Hysteresis in the ring detector Schmitt trigger stretches the output pulse such that the falling edge occurs near the zero crossing following the point where the ring detect threshold was exceeded. The duty cycle of the output depends on the magnitude of the ring signal.

The half-wave version generates a single ring pulse for each half wave of the AC sinusoid. The full-wave version generates a ring pulse for both halves of the AC sinusoid. For many applications, half-wave versions suffice. Many modem data pumps require half-wave detection.

4.2 Off-Hook Operation

4.2.1 Switchhook, DC Termination, and Gyator (Electronic Inductor) Circuits

Figure 5. DC Termination Circuit

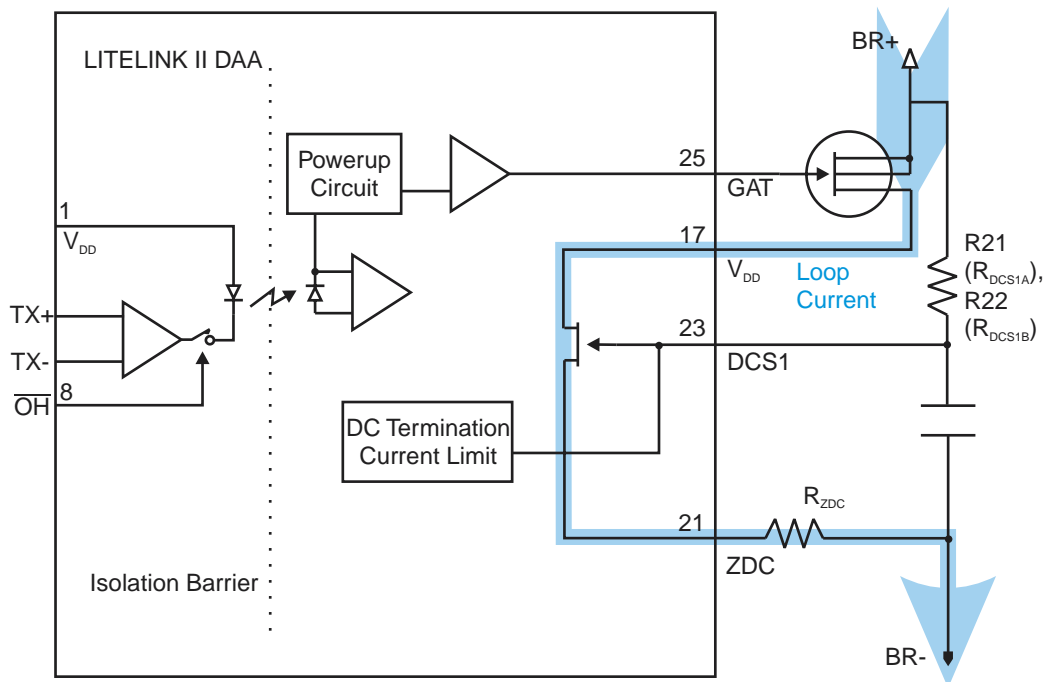

NOTE: External component designations reference Clare, Inc. application circuits.

DC termination occurs when the LITELINK II DAA places the telephone line in the off-hook state. Pulling OH low causes the power-up circuit to drive the regulator FET across the isolation barrier. The DC path is now complete: through the regulator, the internal FET, and R_{ZDC} .

R_{DCS1} , R_{DCS2} , and R_{ZDC} can be adjusted such that a particular VI (voltage/current) slope can be achieved. Some locations require that, given a particular voltage on tip and ring, there must be a certain amount of loop current. Check the requirements of your application for specific VI slope information.

Different DC terminations are accomplished by means of a gyator (electronic inductor) circuit. Off-hook operation requires a low DC resistance across tip and ring of 200 Ω to 300 Ω or less, while AC impedance must be between 600 Ω and 900 Ω (for North American applications).

The impedance of the circuit across tip and ring is the AC signal voltage divided by the current due to the AC signal, or:

$$Z = \frac{V_{AC}\langle SIGNAL \rangle}{I\langle SIGNAL \rangle}$$

The RC network (R_{21} , R_{22} , and C_{12} in the DC termination circuit shown in Clare, Inc. application circuits) is across tip and ring, so any AC signal appears across this network. R_{21} , R_{22} , and C_{12} are valued so as to have a time constant long enough to prevent AC signals in the telephone passband of 30 Hz to 4 kHz from modulating the gate voltage of the internal FET.

If the gate of the internal FET is not modulated by the signal then the signal current is essentially zero and the AC impedance across tip and ring is very high, much higher than 600 Ω and 900 Ω . This constitutes a gyator circuit designed for low DC resistance while maintaining high AC impedance.

4.2.2 AC Termination

Figure 6. AC Termination Circuit

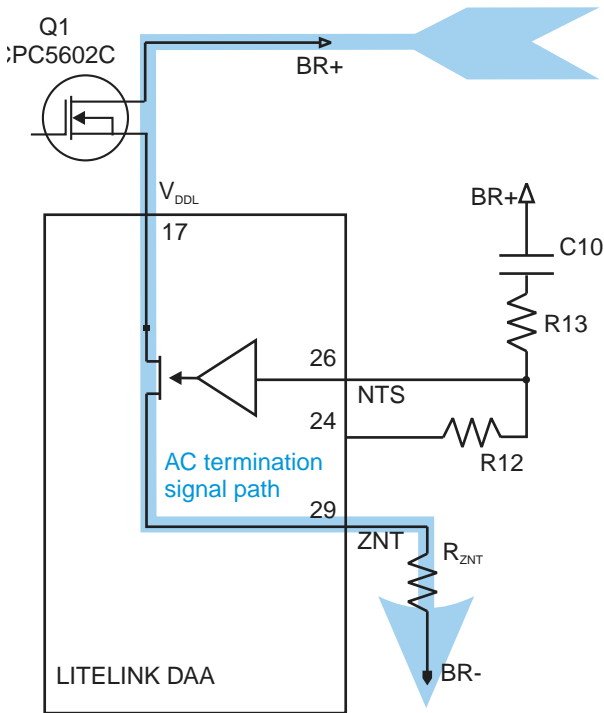

NOTE: External component designations reference Clare, Inc. application circuits.

The LITELINK II DAA can adapt to market-specific impedance requirements by careful selection of the external components. Designs for areas that require complex impedance, including Europe, Australia, South Africa, Mexico, etc., require replacement of R_{ZNT} with an RC network. See the [LITELINK data sheets](#) and [application notes](#) for more information.

The AC impedance of the LITELINK II DAA (shown in Figure 6) is set by R_{ZNT} . The network comprised of C10, R12, and R13 (from the Clare, Inc. application circuits) divides the line voltage. The signal is coupled to a LITELINK II DAA internal amplifier which converts the voltage signal to a current which flows in R_{ZNT} . For example, if R_{ZNT} is 300 Ω and the signal on the line is halved, the circuit presents an effective AC impedance of 600 Ω to the line. Impedance in the AC termination circuit is:

$$Z = \frac{V_{AC}\langle SIGNAL \rangle}{I\langle SIGNAL \rangle}$$

Note that the voltage signal on tip and ring is composed of both transmit and receive signals, since the LITELINK II DAA is full duplex. This creates a current signal in R_{ZNT} that modulates the loop current. The voltage at the ZNT pin of the LITELINK II DAA should be the same signal that is on the telephone line, reduced in amplitude by the C10, R12, and R13 network.

4.2.3 Transmitting the Signal from TX+ and TX- to the Telephone Line

Figure 7. TX Signal Coupling

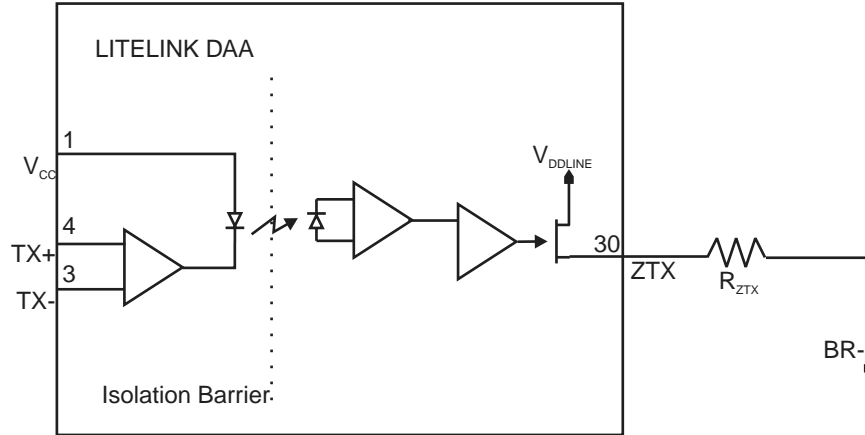

NOTE: External component designations reference Clare, Inc. application circuits.

You apply the transmit signal from the CPE to TX+ and TX- as a differential signal or single-ended signal (as shown in Figure 7). This signal is converted to light and modulated across the isolation barrier. The output of photodiode amplifier drives a voltage to current converter, and the transmit signal voltage appears on the ZTX pin. The transmit voltage is 180° out-of-phase with the transmit signal that appears on the line. The phase relationship of the signals becomes important in discussion of the hybrid circuit below. The transmit signal voltage creates a current on the line that represents the transmit signal.

4.2.4 The Hybrid Circuit

Figure 8. Hybrid Circuit Block Diagram

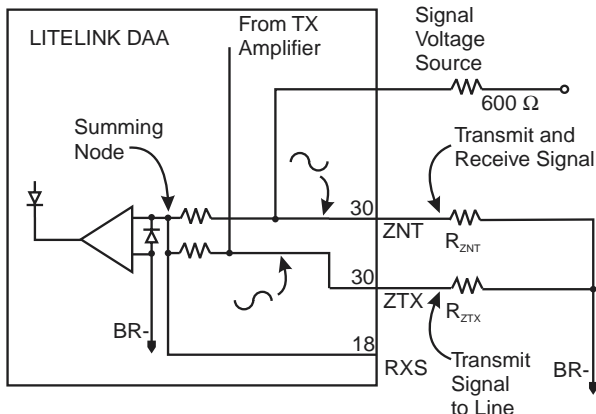

The hybrid circuit performs two functions; converting the four-wire signals (RX+, RX-, TX+, TX-) for use with

two-wire transmission (tip and ring); and reduction of the transmit signal in the receive path.

For a fixed set of external resistor values, the LITELINK II DAA is optimized for a particular fixed impedance telephone line. If the line impedance doesn't exactly match the fixed network, then more transmit signal will appear in the receive path, as with all hybrid circuits.

As shown in Figure 8, the signal that appears on ZTX is the transmit signal from the CPE. It is well-controlled with a certain amplitude and phase. The voltage and phase at ZNT is dependent on the impedance of the telephone line and other line impairments.

The following analysis of the operation of the hybrid assumes the following:

1. The impedance of the telephone line is 600 Ω resistive and therefore has no phase shift associated with the signal.
2. The summing node resistors are exactly the same value.
3. A signal is being transmitted to the line but no signal is being received.

Since there is no phase shift due to any telephone line impairments, the signal on ZTX and ZNT are precisely the same amplitude and exactly 180° phase shifted from each other. The summing node resistors are exactly the same value and one end of each resistor is connected together to form the summing node. Because the signals are 180° out of phase and the

amplitude is equal, the resultant signal current at the summing node is zero and all of the transmit signal has been cancelled.

If the line impedance is not 600 Ω, more transmit signal will be coupled into the summing node. If we send a receive signal from the CO while simultaneously transmitting a signal, then only the receive signal will be injected into the summing node (since the transmit signal has been cancelled) and will be processed to the RX+ and RX- outputs.

4.2.5 Trans-Hybrid Loss

To measure the rejection of transmit signal from the receive path, connect a known transmit signal on TX+ and TX- and then measure the signal at RX+ and RX-. This figure of merit is known as trans-hybrid loss (THL), expressed:

$$THL (dB) = 20 \log \left(\frac{V (RX +, RX -)}{V (TX +, TX -)} \right) dB$$

5. Surge Protection

In the United States and Canada there are two groups of surge protection requirements:

1. Power-line cross protection requirements, where power lines come in contact with telephone lines, based on the requirements of the UL1950 safety standard, and
2. Requirements based on TIA/EIA-IS-968/IC CS 03 (formerly known as FCC part 68). These surges can be metallic (from tip to ring), or longitudinal (from tip or ring to ground).

All of the requirements can be met with a LITELINK II DAA and surge protection circuitry as shown below.

exceed any of the component voltage ratings in the LITELINK II DAA line-side circuit. For a LITELINK II DAA circuit, it is recommended that the surge device be a solid-state Thyristor device with a turn-on voltage not exceeding 320 Vdc. Please visit the [Teccor](#) web site for details on surge protection devices and applications.

A LITELINK II DAA is sufficiently protected against metallic surges by the use of a Sidactor across the phone lines. The Teccor P3100SB Sidactor complies with the requirements of FCC part 68. For compliance with IEC 1000-4-5 and GR-1089, use the Teccor P3100SC sidactor and appropriate current limiting in series with the tip and ring leads.

5.1 Metallic Protection

5.2 Longitudinal Protection

For basic longitudinal protection, the LITELINK II DAA optical isolation barrier will withstand 1.5 kV_{RMS}.

Figure 9. Metallic Circuit Protection

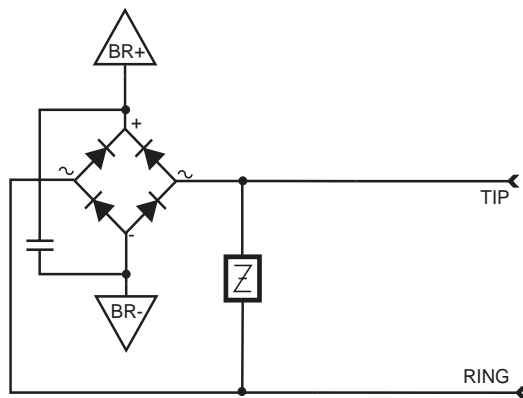

Figure 10 shows a simplified diagram of a metallic surge protection scheme. Select the surge protector to clamp the surge voltage such that the voltage does not

6. LITELINK Design Resources

6.1 Clare, Inc. Design Resources

The Clare, Inc. web site has a wealth of information useful for designing with LITELINK, including application notes and reference designs that already meet all applicable regulatory requirements. LITELINK data sheets also contains additional application and design information. See the following links:

LITELINK datasheets and reference designs

Application note AN-107 **LOCxx Series - Isolated Amplifier Design Principles**

Application note AN-114 **ITC117P**

Application note AN-117 **Customize Caller-ID Gain and Ring Detect Voltage Threshold for CPC5610/11**

Application note AN-141, **Enhanced Pulse Dialing with LITELINK**

Application note AN-143, **Loop Reversal Detection with LITELINK**

Application note AN-146, **Guidelines for Effective LITELINK Designs**

Application note AN-147, **Worldwide Application of LITELINK**

Application note AN-149, **Increased LITELINK II Transmit Power**

Application note AN-150, **Ground-start Supervision Circuit Using IAA110.**

Photodiode Amplifiers: Op Amp Solutions, Jerald Graeme, McGraw-Hill Professional Publishing; ISBN: 007024247X

Teccor, Inc. Surge Protection Products

United States Code of Federal Regulations, CFR 47 Part 68.3

6.2 Third Party Design Resources

The following also contain information useful for DAA designs. All of the books are available on amazon.com.

Understanding Telephone Electronics, Stephen J. Bigelow, et. al., Butterworth-Heinemann; ISBN: 0750671750

Newton's Telecom Dictionary, Harry Newton, CMP Books; ISBN: 1578200695

For additional information please visit www.clare.com

Clare, Inc. makes no representations or warranties with respect to the accuracy or completeness of the contents of this publication and reserves the right to make changes to specifications and product descriptions at any time without notice. Neither circuit patent licenses or indemnity are expressed or implied. Except as set forth in Clare's Standard Terms and Conditions of Sale, Clare, Inc. assumes no liability whatsoever, and disclaims any express or implied warranty relating to its products, including, but not limited to, the implied warranty of merchantability, fitness for a particular purpose, or infringement of any intellectual property right.

The products described in this document are not designed, intended, authorized, or warranted for use as components in systems intended for surgical implant into the body, or in other applications intended to support or sustain life, or where malfunction of Clare's product may result in direct physical harm, injury, or death to a person or severe property or environmental damage. Clare, Inc. reserves the right to discontinue or make changes to its products at any time without notice.
