



Features

- μPower Operation (15 μW typical at 25°C)
- Omnipolar (switches with N or S pole)
- 2.5V to 5.5V Operation
- CMOS Push-Pull Output
- Ultra Low Offset Canceling Amplifiers Provide Sensitive, Accurate, Stable Switching Points and Immunity to Mechanical Stress
- Solid State Reliability
- Operating Temperature Range: -40°C to +85°C
- RoHS Compliant TSOT23 3-Lead Package

Applications

- Handheld Portable Devices
- White Goods
- Automotive - Body Systems
- Security Systems
- High Reliability Reed Switch Replacement

Description

The MX887P integrated Hall-Effect switch targets the requirements of low-power portable devices with battery operating voltages from 2.5V to 5.5V. On-chip power management circuitry reduces the effective average current to just 5μA at $V_{SUPPLY} = 3V_{DC}$.

The switch output will transition to the Ground potential when either a north or south magnetic pole is applied. The removal of a magnetic field will transition the switch to the V_{SUPPLY} potential. Emulating the behavior of a traditional reed switch, together with the advantages of high integration and solid state reliability, makes the MX887P an ideal replacement in low-power portable device applications.

Ordering Information

Part	Description
MX887PHTTR	TSOT23 3L Tape & Reel (3000/Reel)



Figure 1. Functional Block Diagram

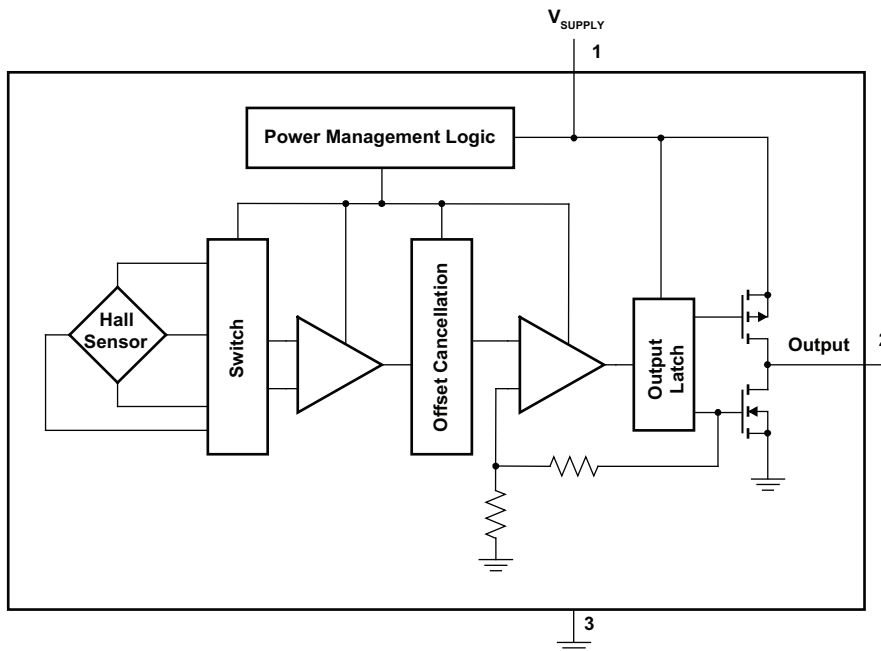

1. Specifications	3
1.1 Package Pinout	3
1.2 Pin Description	3
1.3 Absolute Maximum Ratings	3
1.4 Electrical Characteristics	3
1.5 ESD Rating	4
1.6 Magnetic Characteristics	4
2. Circuit Description	4
3. Manufacturing Information	5
3.1 Moisture Sensitivity	5
3.2 ESD Sensitivity	5
3.3 Reflow Profile	5
3.4 Board Wash	5
3.5 Mechanical Dimensions	6

1 Specifications

1.1 Package Pinout

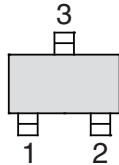

1.2 Pin Description

Pin#	Name	Description
1	V _{SUPPLY}	2.5V to 5.5V
2	OUT	Push-Pull CMOS Output
3	GROUND	Ground

1.3 Absolute Maximum Ratings

Parameter	Symbol	Min	Max	Units
Supply Voltage	V _{SUPPLY}	-0.5	6	V _{DC}
Output Voltage	V _{OUT}	-0.5	6	V
Magnetic Flux Density	B	-	Unlimited	G
Output Current	-	-	5	mA
Junction Temperature	T _J	-	150	°C
Operating Ambient Temperature	T _A	-40	85	
Storage Temperature	T _{STG}	-40	150	

Absolute maximum electrical ratings are at 25°C.

Absolute maximum ratings are stress ratings. Stresses in excess of these ratings can cause permanent damage to the device. Functional

operation of the device at conditions beyond those indicated in the operational sections of this data sheet is not implied.

1.4 Electrical Characteristics

Over operating voltage and temperature range unless otherwise specified.

Parameter	Conditions	Symbol	Minimum	Typical	Maximum	Units
Supply Voltage Range	Operating	V _{SUPPLY}	2.5	-	5.5	V _{DC}
Output Leakage Current	V _{OUT} =5.5V, B _{RPN} < B < B _{RPS}	I _{LKG}	-	-	1	μA
Output On Voltage	I _{OUT} =1mA, V _{DD} =3.0V	V _{OUT}	-	100	300	mV
Awake Time	-	-	-	-	90	μs
Period	-	-	-	-	90	ms
Duty Cycle	-	-	-	0.1	-	%
Supply Current	Awake (enabled)	I _{SUPPLY}	-	-	2	mA
	Asleep (disabled)		-	-	8	μA
	Average (Calculated)		-	5	15	μA

- Notes: 1. B_{OPX} = operating point (output turns ON); B_{RPX} = release point (output turns OFF).
 2. Typical data is at 25°C and V_{SUPPLY} = 3V.

1.5 ESD Rating

ESD Rating (Human Body Model)
2000V

1.6 Magnetic Characteristics

Over operating voltage and temperature range unless otherwise specified.

Parameter	Conditions	Symbol	Minimum	Typical	Maximum	Units
Operating Points						
Due to North Pole Applied	North Pole to Branded Side	B _{OPN}	-60	-	-	G
Due to South Pole Applied	South Pole to Branded Side	B _{OPS}	-	-	60	
Release Points						
Due to North Pole Applied	North Pole to Branded Side	B _{RPN}	-	-	-6	G
Due to South Pole Applied	South Pole to Branded Side	B _{RPS}	6	-	-	
Hysteresis	B _{OPX} - B _{RPX}	B _{HYS}	-	5	-	G

- Notes:
1. As used here, negative flux densities are defined as less than zero (algebraic convention); -50G<+10G.
 2. B_{OPX} = operating point (output turns ON); B_{RPX} = release point (output turns OFF).
 3. Typical data is at 25°C and V_{SUPPLY} = 3V.

2 Circuit Description

The MX887P μ Power Hall-Effect Switch consists of a Hall element, small-signal amplifier, latch, and CMOS push-pull output. Offset cancellation circuitry rejects errors in signal stages and the influence of mechanical stress on the Hall element. This technique, together with a precision threshold generator and comparator,

produces highly accurate magnetic switch points. The Hall element is activated for a small fraction of an operating cycle, then latched in that sample state for the remainder of the period. By using this technique, very low power consumption is achieved.

3 Manufacturing Information

3.1 Moisture Sensitivity



All plastic encapsulated semiconductor packages are susceptible to moisture ingress. Clare classified all of its plastic encapsulated devices for moisture sensitivity according to the latest version of the joint industry standard, **IPC/JEDEC J-STD-020**, in force at the time of product evaluation. We test all of our products to the maximum conditions set forth in the standard, and guarantee proper operation of our devices when handled according to the limitations and information in that standard as well as to any limitations set forth in the information or standards referenced below.

Failure to adhere to the warnings or limitations as established by the listed specifications could result in reduced product performance, reduction of operable life, and/or reduction of overall reliability.

This product carries a **Moisture Sensitivity Level (MSL) rating** as shown below, and should be handled according to the requirements of the latest version of the joint industry standard **IPC/JEDEC J-STD-033**.

Device	Moisture Sensitivity Level (MSL) Rating
MX887P	MSL 3

3.2 ESD Sensitivity



This product is **ESD Sensitive**, and should be handled according to the industry standard **JESD-625**.

3.3 Reflow Profile

This product has a maximum body temperature and time rating as shown below. All other guidelines of **J-STD-020** must be observed.

Device	Maximum Temperature x Time
MX887P	260°C for 30 seconds

3.4 Board Wash

Clare recommends the use of no-clean flux formulations. However, board washing to remove flux residue is acceptable, and the use of a short drying bake may be necessary. Chlorine-based or Fluorine-based solvents or fluxes should not be used. Cleaning methods that employ ultrasonic energy should not be used.



3.5 Mechanical Dimensions

3.5.1 TSOT23 3-Lead Package

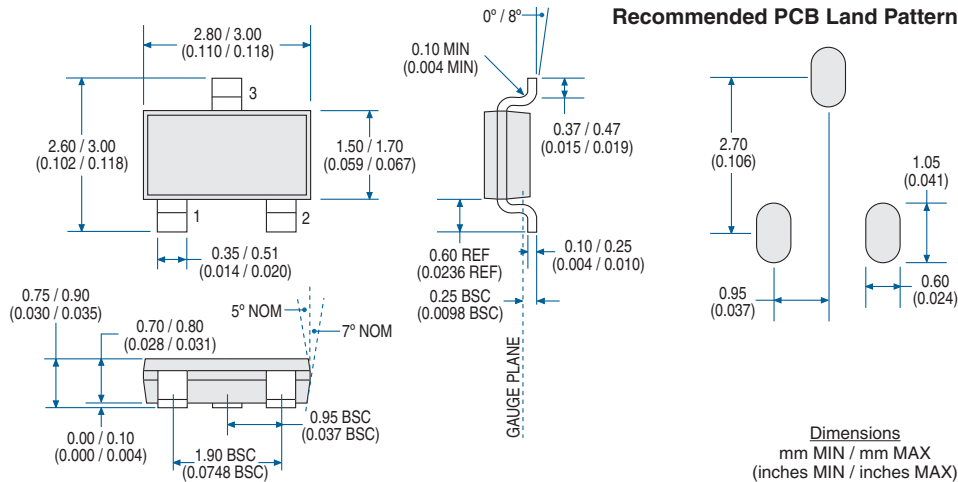

Notes: (Unless otherwise specified)

1. Dimension "D" does not include mold flash, protrusions, or gate burrs. Mold flash, protrusions, and gate burrs shall not exceed 0.10mm (0.004 inches) per side.
2. Dimension "E" does not include inter-lead flash or protrusions. Inter-lead flash and protrusions shall not exceed 0.15mm (0.006 inches) per side.
3. Package top may be smaller than package bottom. Dimensions "D" and "E1" are determined at the outermost extreme of the plastic body excluding mold flash, tie bar burrs, gate burrs, and interlead flash, but including any mismatch between top and bottom of the plastic body.

3.5.2 Tape & Reel Packaging

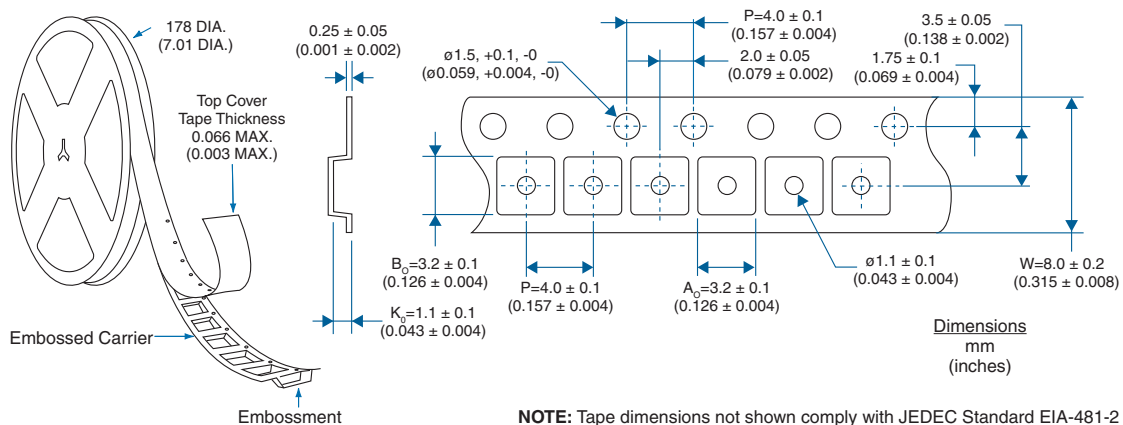

For additional information please visit our website at: www.clare.com

Clare, Inc. makes no representations or warranties with respect to the accuracy or completeness of the contents of this publication and reserves the right to make changes to specifications and product descriptions at any time without notice. Neither circuit patent licenses nor indemnity are expressed or implied. Except as set forth in Clare's Standard Terms and Conditions of Sale, Clare, Inc. assumes no liability whatsoever, and disclaims any express or implied warranty, relating to its products including, but not limited to, the implied warranty of merchantability, fitness for a particular purpose, or infringement of any intellectual property right.

The products described in this document are not designed, intended, authorized or warranted for use as components in systems intended for surgical implant into the body, or in other applications intended to support or sustain life, or where malfunction of Clare's product may result in direct physical harm, injury, or death to a person or severe property or environmental damage. Clare, Inc. reserves the right to discontinue or make changes to its products at any time without notice.

Specification: DS-MX887P-20110729
©Copyright 2011, Clare, Inc.
All rights reserved. Printed in USA.
7/29/2011