



### Features

- μPower Operation (15 μW typical at 25°C)
- Omnipolar (switches with N or S pole)
- 2.5V to 5.5V Operation
- Simple Digital Open-Drain Output
- Ultra Low Offset Canceling Amplifiers Provide Sensitive, Accurate, Stable Switching Points and Immunity to Mechanical Stress
- Solid State Reliability
- Operating Temperature Range: -40°C to +85°C
- RoHS Compliant TSOT-23 3-Lead Package

### Applications

- Handheld Portable Devices
- White Goods
- Automotive - Body Systems
- Security Systems
- High Reliability Reed Switch Replacement

### Description

The MX887D integrated Hall-Effect switch targets the requirements of low-power portable devices with battery operating voltages from 2.5V to 5.5V. On-chip power management circuitry reduces the effective average current to just 5μA at  $V_{SUPPLY} = 3V_{DC}$ .

The switch output will turn “on” when either a north or south magnetic pole is applied. The absence of a magnetic field will set the switch into the high-impedance “off” state. Emulating the behavior of a traditional reed switch, together with the advantages of high integration and solid state reliability, makes the MX887D an ideal replacement in low-power portable device applications.



### Ordering Information

Part	Description
MX887DHTTR	TSOT-23 3L Tape & Reel (3000/Reel)

Figure 1. Functional Block Diagram

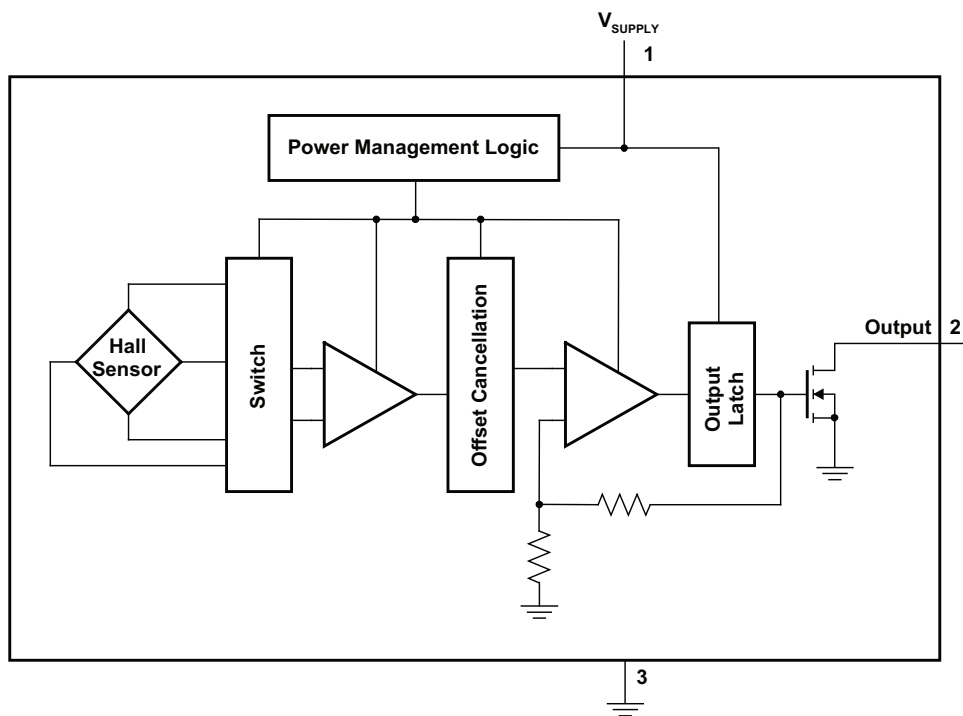

---

<b>1. Specifications</b> .....	<b>3</b>
1.1 Package Pinout .....	3
1.2 Pin Description .....	3
1.3 Absolute Maximum Ratings .....	3
1.4 Electrical Characteristics .....	3
1.5 ESD Rating .....	4
1.6 Magnetic Characteristics .....	4
<b>2. Circuit Description</b> .....	<b>4</b>
<b>3. Manufacturing Information</b> .....	<b>5</b>
3.1 Mechanical Dimensions .....	5
3.2 Soldering .....	6
3.3 Washing .....	6

## 1 Specifications

### 1.1 Package Pinout

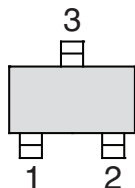

### 1.2 Pin Description

Pin#	Name	Description
1	V <sub>SUPPLY</sub>	2.5V to 5.5V
2	OUT	Open-Drain, N-Channel FET
3	GROUND	Ground

### 1.3 Absolute Maximum Ratings

Parameter	Symbol	Min	Max	Units
Supply Voltage	V <sub>SUPPLY</sub>	-0.5	6	V <sub>DC</sub>
Output Voltage	V <sub>OUT</sub>	-0.5	6	V
Magnetic Flux Density	B	-	Unlimited	G
Output Current	I <sub>OUT</sub>	-	5	mA
Junction Temperature	T <sub>J</sub>	-	150	°C
Operating Ambient Temperature	T <sub>A</sub>	-40	85	
Storage Temperature	T <sub>STG</sub>	-40	150	

Absolute maximum electrical ratings are at 25°C.

Absolute maximum ratings are stress ratings. Stresses in excess of these ratings can cause permanent damage to the device. Functional

operation of the device at conditions beyond those indicated in the operational sections of this data sheet is not implied.

### 1.4 Electrical Characteristics

Over operating voltage and temperature range unless otherwise specified.

Parameter	Conditions	Symbol	Minimum	Typical	Maximum	Units
Supply Voltage Range	Operating	V <sub>SUPPLY</sub>	2.5	-	5.5	V <sub>DC</sub>
Output Leakage Current	V <sub>OUT</sub> =5.5V, B <sub>RPX</sub> < B < B <sub>RPS</sub>	I <sub>LKG</sub>	-	-	1	μA
Output On Voltage	I <sub>OUT</sub> =1mA, V <sub>DD</sub> =3.0V	V <sub>OUT</sub>	-	100	300	mV
Awake Time	-	-	-	-	90	μs
Period	-	-	-	-	90	ms
Duty Cycle	-	-	-	0.1	-	%
Supply Current	Awake (enabled)	I <sub>SUPPLY</sub>	-	-	2	mA
	Asleep (disabled)		-	-	8	μA
	Average (Calculated)		-	5	15	μA

- Notes:
1. B<sub>OPX</sub> = operating point (output turns ON); B<sub>RPX</sub> = release point (output turns OFF).
  2. Typical data is at 25°C and V<sub>SUPPLY</sub> = 3V.

**1.5 ESD Rating**

<b>ESD Rating (Human Body Model)</b>
2000V

**1.6 Magnetic Characteristics**

Over operating voltage and temperature range unless otherwise specified.

Parameter	Conditions	Symbol	Minimum	Typical	Maximum	Units
Operating Points						
Due to North Pole Applied	North Pole to Branded Side	B <sub>OPN</sub>	-60	-	-	G
Due to South Pole Applied	South Pole to Branded Side	B <sub>OPS</sub>	-	-	60	
Release Points						
Due to North Pole Applied	North Pole to Branded Side	B <sub>RPN</sub>	-	-	-6	G
Due to South Pole Applied	South Pole to Branded Side	B <sub>RPS</sub>	6	-	-	
Hysteresis	B <sub>OPX</sub> - B <sub>RPX</sub>	B <sub>HYS</sub>	-	5	-	G

- Notes:
1. As used here, negative flux densities are defined as less than zero (algebraic convention); -50G<+10G.
  2. B<sub>OPX</sub> = operating point (output turns ON); B<sub>RPX</sub> = release point (output turns OFF).
  3. Typical data is at 25°C and V<sub>SUPPLY</sub> = 3V.

**2 Circuit Description**

The MX887D  $\mu$ Power Hall-Effect Switch consists of a Hall element, small signal amplifier, latch, and N-channel open-drain output. Offset cancellation circuitry rejects errors in signal stages and the influence of mechanical stress on the Hall element. This technique, together with a precision threshold generator and comparator, produces highly accurate magnetic switch points. The Hall element is activated for a small fraction of an operating cycle, then latched in that sample state for the remainder of the period. By using this technique, very low power consumption is achieved.

### 3 Manufacturing Information

#### 3.1 Mechanical Dimensions

##### 3.1.1 TSOT23 3-Lead Package

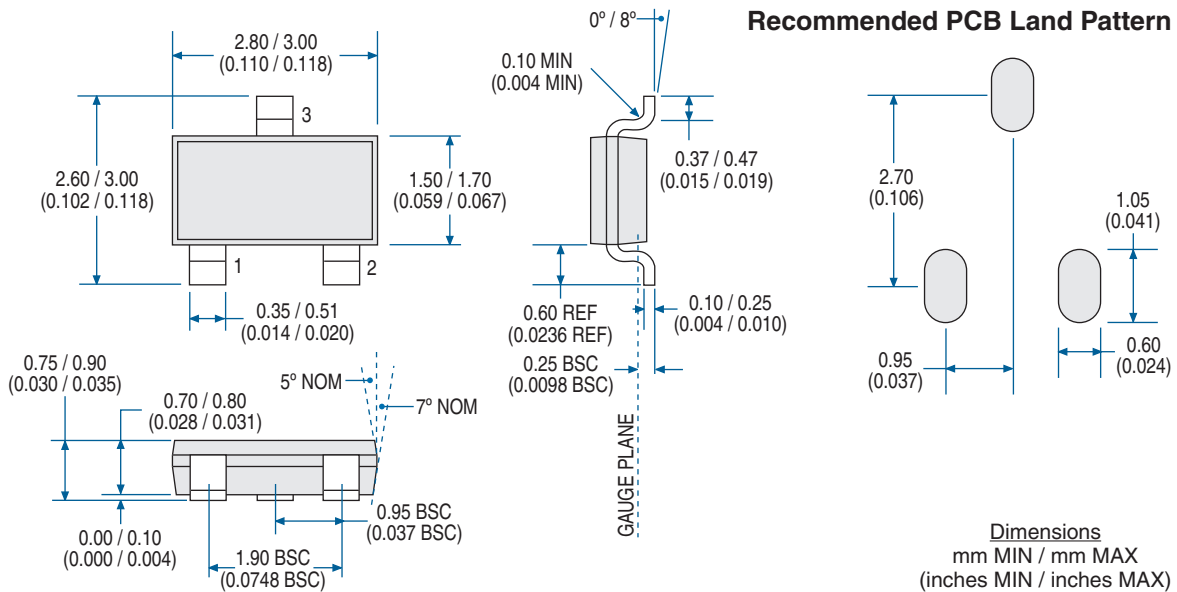

Notes: (Unless otherwise specified)

1. Dimension "D" does not include mold flash, protrusions, or gate burrs. Mold flash, protrusions, and gate burrs shall not exceed 0.10mm (0.004 inches) per side.
2. Dimension "E" does not include inter-lead flash or protrusions. Inter-lead flash and protrusions shall not exceed 0.15mm (0.006 inches) per side.
3. Package top may be smaller than package bottom. Dimensions "D" and "E1" are determined at the outermost extreme of the plastic body excluding mold flash, tie bar burrs, gate burrs, and interlead flash, but including any mismatch between top and bottom of the plastic body.

##### 3.1.2 Tape & Reel Packaging

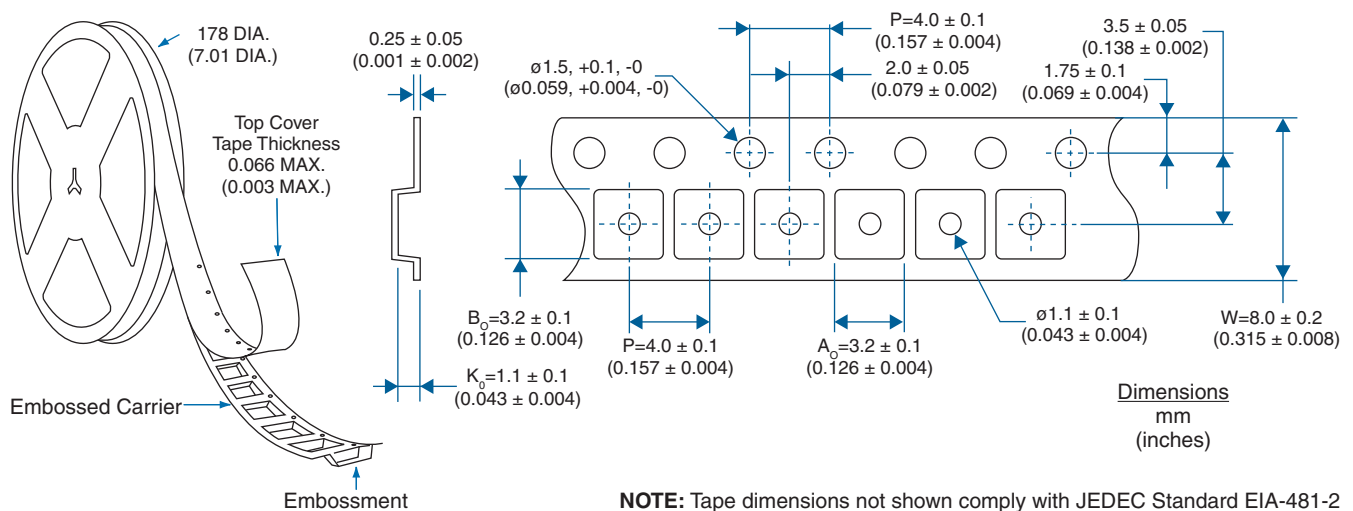

**3.2 Soldering**

For proper assembly, the component must be processed in accordance with the current revision of IPC/JEDEC standard J-STD-020. Failure to follow the recommended guidelines may cause permanent damage to the device resulting in impaired performance and/or a reduced lifetime expectancy.

**3.3 Washing**

Clare does not recommend ultrasonic cleaning or the use of chlorinated hydrocarbons.



**For additional information please visit our website at: [www.clare.com](http://www.clare.com)**

Clare, Inc. makes no representations or warranties with respect to the accuracy or completeness of the contents of this publication and reserves the right to make changes to specifications and product descriptions at any time without notice. Neither circuit patent licenses nor indemnity are expressed or implied. Except as set forth in Clare's Standard Terms and Conditions of Sale, Clare, Inc. assumes no liability whatsoever, and disclaims any express or implied warranty, relating to its products including, but not limited to, the implied warranty of merchantability, fitness for a particular purpose, or infringement of any intellectual property right.

The products described in this document are not designed, intended, authorized or warranted for use as components in systems intended for surgical implant into the body, or in other applications intended to support or sustain life, or where malfunction of Clare's product may result in direct physical harm, injury, or death to a person or severe property or environmental damage. Clare, Inc. reserves the right to discontinue or make changes to its products at any time without notice.

Specification: DS-MX887D-August 10, 2009  
©Copyright 2009, Clare, Inc.  
All rights reserved. Printed in USA.  
8/10/09