



## Features

- 3V to 60V Operating Voltage Range
- Integrated 10-bit ADC
- 3-Wire Serial Interface
- Microcontroller Compatible
- Low Power
- Minimum External Components
- TSOT23 RoHS Compliant Package

## Applications

- Lighting Management
- Current Shunt Measurement
- Remote Sensing
- Battery Monitoring
- Microprocessor Controlled Power Management

## Description

The MX884 targets power management applications where high noise immunity and low cost are primary requirements. Its integrated 10-bit ADC provides high resolution, making it ideal for current monitoring systems. The MX884 enables digital power management, in which a microcontroller can readily monitor the current in a system, and perform other control functions in power systems and motion control products.

The MX884 converts a small voltage developed across an external current-sense resistor into a 10-bit digital output. It features a wide common mode input supply voltage range of 3V to 60V, and easily interfaces to most microcontrollers. The design is simple yet cost-effective, requiring very few external components, which makes it especially suitable for high volume applications.

## Ordering Information

Part	Description
MX884HTTR	TSOT23 6-Lead, Tape & Reel (3,000/Reel)

## Functional Block Diagram

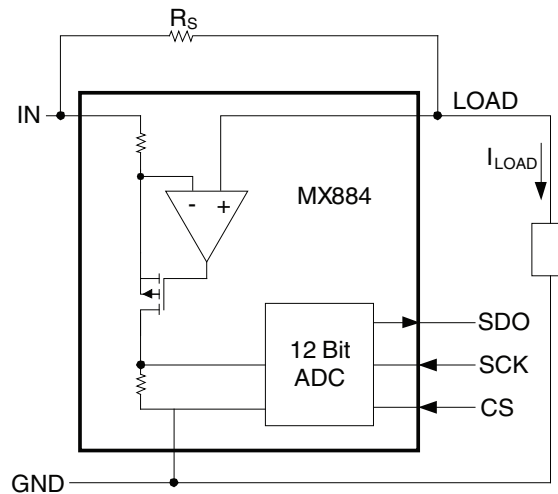

---

<b>1. Specifications</b> .....	<b>3</b>
1.1 Package Pinout .....	3
1.2 Pin Description .....	3
1.3 Absolute Maximum Ratings .....	3
1.4 DC Electrical Characteristics .....	3
<b>2. Functional Description</b> .....	<b>4</b>
<b>3. Manufacturing Information</b> .....	<b>5</b>
3.1 Moisture Sensitivity .....	5
3.2 ESD Sensitivity .....	5
3.3 Reflow Profile .....	5
3.4 Mechanical Dimensions .....	6

## 1 Specifications

### 1.1 Package Pinout

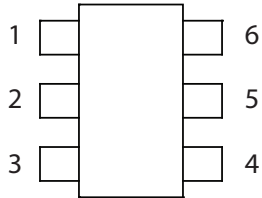

### 1.2 Pin Description

Pin#	Name	Description
1	SCK	Serial Clock
2	GND	Ground
3	LOAD	Load-Side Connection to the External Sense Resistor
4	IN	Positive Supply Terminal and Power Connection for the External Sense Resistor
5	CS	Chip Select (Active Low)
6	SDO	Serial Data Output (Open Drain)

### 1.3 Absolute Maximum Ratings

Parameter	Symbol	Min	Max	Units
IN Supply Voltage	-	-	70	V
LOAD	-	-	70	V
SCK, CS Input Voltage	-	-	6	V
SDO Open Drain Pull-Up Voltage	-	-	6	V
Operating Temperature Range	T <sub>A</sub>	-40	+85	°C
Storage Temperature Range	T <sub>STG</sub>	-55	+150	°C

Absolute maximum ratings are stress ratings. Stresses in excess of these ratings can cause permanent damage to the device. Functional operation of the device at conditions beyond those indicated in the operational sections of this data sheet is not implied.

Absolute maximum electrical ratings are at 25°C

### 1.4 DC Electrical Characteristics

V<sub>IN</sub>=5V, T<sub>A</sub>=25°C.

Parameter	Conditions	Minimum	Typical	Maximum	Units
Operating Voltage Range (V <sub>IN</sub> )	-	3	-	60	V
Supply Current	I <sub>LOAD</sub> =0	-	0.25	-	mA
Average A/D Reading	10mV Sense Voltage	90	100	110	LSB
Average A/D Reading	100mV Sense Voltage	992	1000	1008	LSB
Output Noise	C <sub>S</sub> =10nF Parallel, R <sub>S</sub> =10Ω	-	1.5	-	RMS LSB
SCK Pulse Period	-	5	-	-	μs
SCK Pulse Width	High or Low	200	-	-	ns
CS Pulse Period	-	100	-	-	μs
CS Falling to First SCK Rising	-	200	-	-	ns
Last SCK Falling to CS Rising	-	100	-	-	ns
SCK Falling to SDO Valid	SDO Falling	-	-	80	ns
	SDO Rising	Depends on SDO R, C			-

## 2 Functional Description

The MX884 converts a small voltage developed across an external sense resistor ( $R_s$ ) to a 10-bit digital output. Pin IN connects to the 3V to 60V power input. The external current sense resistor connects between pins IN and LOAD. The nominal A/D range is 100 mV  $V(IN)-V(LOAD)$  across  $R_s$ . The A/D least significant bit typically equals 0.1 mV across  $R_s$ .

Inputs CS and SCK are TTL-level compatible, 5.5V maximum input voltage. Inputs can be driven from CMOS microcontrollers operating at supply voltages of 2.4 to 5.5V. Serial data output pin SDO is configured as open drain, maximum 5.5V external pull-up. SCK is used internally to clock the successive approximation register of the A/D.

**Figure 1. Serial Timing Diagram**

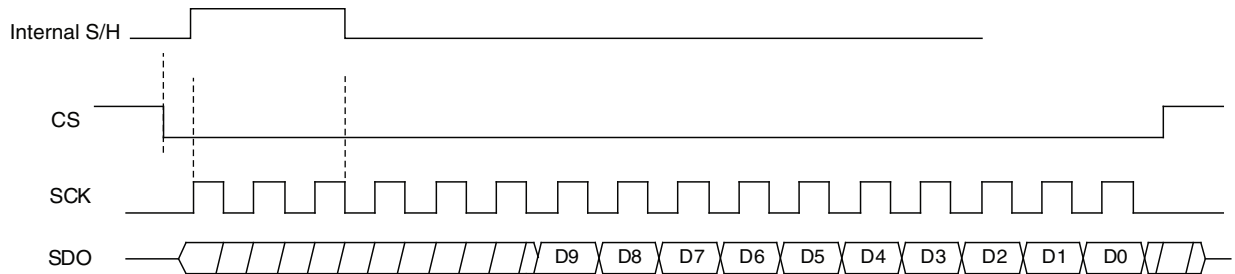

**Figure 2. Typical Application Circuit**

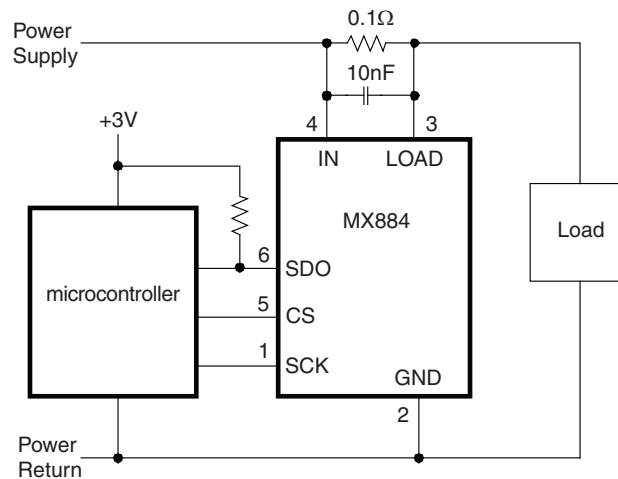

### 3 Manufacturing Information

#### 3.1 Moisture Sensitivity



All plastic encapsulated semiconductor packages are susceptible to moisture ingress. Clare classified all of its plastic encapsulated devices for moisture sensitivity according to the latest version of the joint industry standard, **IPC/JEDEC J-STD-020**, in force at the time of product evaluation. We test all of our products to the maximum conditions set forth in the standard, and guarantee proper operation of our devices when handled according to the limitations and information in that standard as well as to any limitations set forth in the information or standards referenced below.

Failure to adhere to the warnings or limitations as established by the listed specifications could result in reduced product performance, reduction of operable life, and/or reduction of overall reliability.

This product carries a **Moisture Sensitivity Level (MSL) rating** as shown below, and should be handled according to the requirements of the latest version of the joint industry standard **IPC/JEDEC J-STD-033**.

Device	Moisture Sensitivity Level (MSL) Rating
MX884HTTR	MSL 3

#### 3.2 ESD Sensitivity



This product is **ESD Sensitive**, and should be handled according to the industry standard **JESD-625**.

#### 3.3 Reflow Profile

This product has a maximum body temperature and time rating as shown below. All other guidelines of **J-STD-020** must be observed.

Device	Maximum Temperature x Time
MX884HTTR	260°C for 30 seconds



### 3.4 Mechanical Dimensions

#### 3.4.1 TSOT23-6 Package

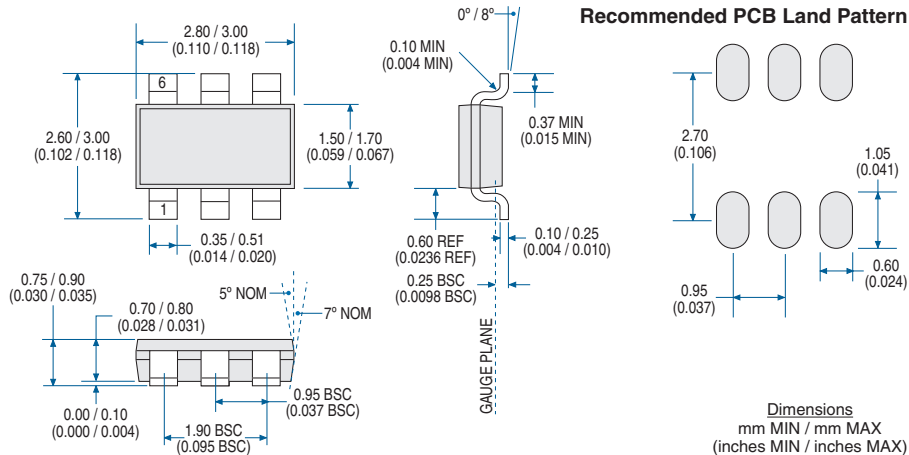

Notes: (Unless otherwise specified)

1. Dimension "D" does not include mold flash, protrusions, or gate burrs. Mold flash, protrusions, and gate burrs shall not exceed 0.10mm (0.004 inches) per side.
2. Dimension "E" does not include inter-lead flash or protrusions. Inter-lead flash and protrusions shall not exceed 0.15mm (0.006 inches) per side.
3. Package top may be smaller than package bottom. Dimensions "D" and "E1" are determined at the outermost extreme of the plastic body excluding mold flash, tie bar burrs, gate burrs, and interlead flash, but including any mismatch between top and bottom of the plastic body.

#### 3.4.2 Tape & Reel Dimensions

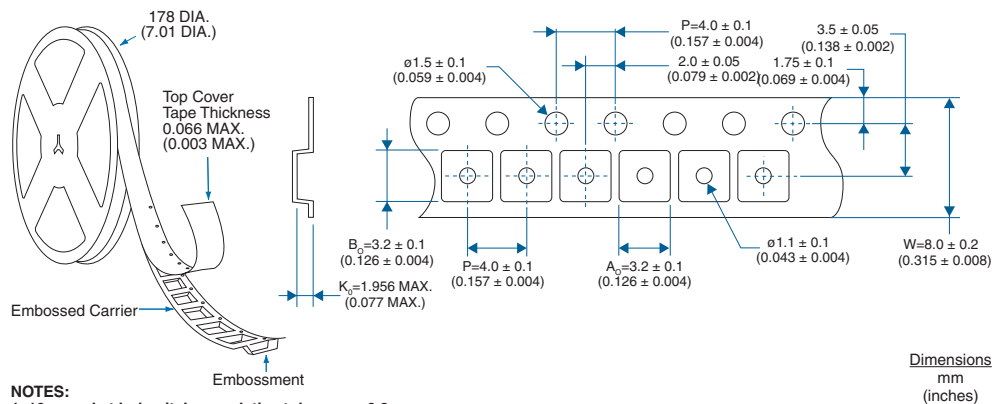

NOTES:

1. 10 sprocket hole pitch cumulative tolerance  $\pm 0.2$
2. Camber not to exceed 1mm in 100mm
3. Pocket position relative to sprocket hole measured as true position of pocket, not pocket hole
4. (S.R. Ohm/Sq.) means surface electric resistivity of the carrier tape.

For additional information please visit our website at: [www.clare.com](http://www.clare.com)

Clare, Inc. makes no representations or warranties with respect to the accuracy or completeness of the contents of this publication and reserves the right to make changes to specifications and product descriptions at any time without notice. Neither circuit patent licenses nor indemnity are expressed or implied. Except as set forth in Clare's Standard Terms and Conditions of Sale, Clare, Inc. assumes no liability whatsoever, and disclaims any express or implied warranty, relating to its products including, but not limited to, the implied warranty of merchantability, fitness for a particular purpose, or infringement of any intellectual property right.

The products described in this document are not designed, intended, authorized or warranted for use as components in systems intended for surgical implant into the body, or in other applications intended to support or sustain life, or where malfunction of Clare's product may result in direct physical harm, injury, or death to a person or severe property or environmental damage. Clare, Inc. reserves the right to discontinue or make changes to its products at any time without notice.

Specification: DS-MX884-20110729  
©Copyright 2011, Clare, Inc.  
All rights reserved. Printed in USA.  
7/29/2011