

### Features

- 16 Push-Pull Outputs Rated at 60V, 15mA
- 6V to 60V Driver Supply Range
- 1.65V to 5.5V Logic Supply Range
- I<sup>2</sup>C Interface
- Synchronous update across multiple packages
- Outputs can be paralleled
- 28-Lead QFN Package

### Applications

- White Goods
- ATE
- Industrial Equipment

### Description

The MX8771 is a 16-channel high-voltage switch with I<sup>2</sup>C serial input control. The MX8771 connects directly to a microprocessor through a standard I<sup>2</sup>C interface. The push-pull output configuration can drive up to 60 volts at 15mA. Outputs can be paralleled for increased drive current up to a device total of 240mA, sink or source.

The MX8771 is designed to operate over a temperature range of -40°C to +85°C, and is available in a QFN-28 Package.

### Ordering Information

Part	Description
MX8771R	QFN-28 (73/Tube)
MX8771RTR	QFN-28 Tape & Reel (2500/Reel)



### Functional Block Diagram

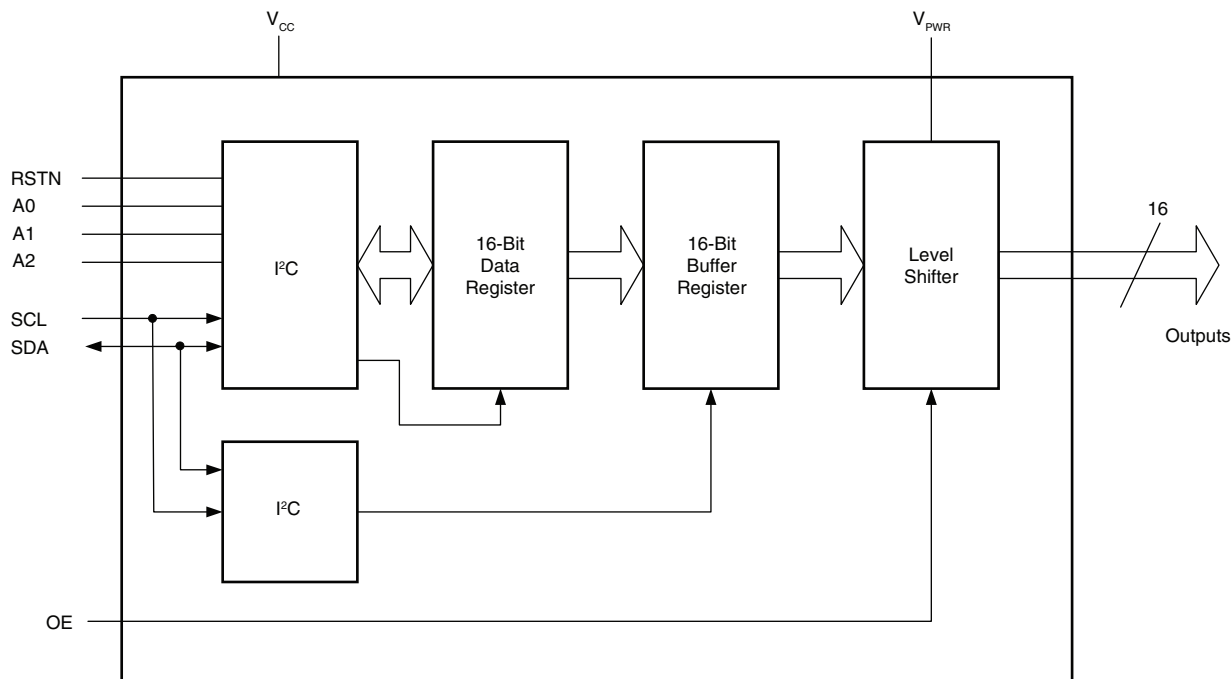

---

<b>1. Specifications</b> .....	<b>3</b>
1.1 Package Pinout .....	3
1.2 Pin Description .....	3
1.3 Absolute Maximum Ratings .....	4
1.4 DC Electrical Characteristics .....	4
1.5 Thermal Characteristics .....	5
1.6 AC Electrical Characteristics .....	5
<b>2. Functional Description</b> .....	<b>6</b>
<b>3. Manufacturing Information</b> .....	<b>7</b>
3.1 Mechanical Dimensions .....	7
3.2 Soldering .....	8
3.3 Washing .....	8

## 1 Specifications

## 1.2 Pin Description

### 1.1 Package Pinout

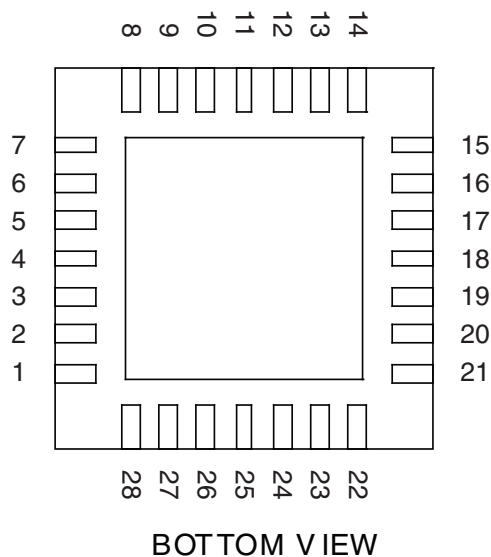

Pin#	Name	Description
1	OUT7	Byte 1, Bit 7 Output
2	GND	Ground
3	GND	Ground
4	V <sub>PWR</sub>	High Voltage Supply
5	V <sub>PWR</sub>	High Voltage Supply
6	V <sub>CC</sub>	Logic Supply
7	OUT15	Byte 2, Bit 7 Output
8	OUT14	Byte 2, Bit 6 Output
9	OUT13	Byte 2, Bit 5 Output
10	OUT12	Byte 2, Bit 4 Output
11	OUT11	Byte 2, Bit 3 Output
12	OUT10	Byte 2, Bit 2 Output
13	OUT9	Byte 2, Bit 1 Output
14	OUT8	Byte 2, Bit 0 Output
15	A0	I2C Device Address
16	A1	I2C Device Address
17	A2	I2C Device Address
18	SDA	I2C Serial Data
19	SCL	I2C Serial Clock
20	OE	Output Enable
21	RSTN	Reset, Active Low
22	OUT0	Byte 1, Bit 0 Output
23	OUT1	Byte 1, Bit 1 Output
24	OUT2	Byte 1, Bit 2 Output
25	OUT3	Byte 1, Bit 3 Output
26	OUT4	Byte 1, Bit 4 Output
27	OUT5	Byte 1, Bit 5 Output
28	OUT6	Byte 1, Bit 6 Output

### 1.3 Absolute Maximum Ratings

Parameter	Symbol	Min	Max	Units
VPWR Supply Voltage	$V_{PWR}$	-	60	V
Logic Supply Voltage	$V_{CC}$	-	6	V
Input Pin Voltage	$V_{IN}$	-	6	V
Continuous Output Current OUT0 - OUT15	$I_{OUTn}$	-	20	mA
Operating Junction Temperature	$T_J$	-	150	°C
Operating Temperature	$T_A$	-40	85	°C
Storage Temperature	$T_{STG}$	-55	150	°C

Absolute maximum electrical ratings are at 25°C

*Absolute Maximum Ratings are stress ratings. Stresses in excess of these ratings can cause permanent damage to the device. Functional operation of the device at these or any other conditions beyond those indicated in the operational sections of this data sheet is not implied. Exposure of the device to the absolute maximum ratings for an extended period may degrade the device and affect its reliability.*

Voltages with respect to GND=0V.

**ESD Warning:** ESD (electrostatic discharge) sensitive device. Although the MX8771 features proprietary ESD protection circuitry, permanent damage may be sustained if subjected to high energy electrostatic discharges. Proper ESD precautions are recommended to avoid performance degradation or loss of functionality.

### 1.4 DC Electrical Characteristics

$V_{CC}=5V$ ,  $V_{PWR}=42V$ ,  $T_A=25^\circ C$ , unless otherwise specified.

Parameter	Conditions		Minimum	Typical	Maximum	Units
Logic Supply Voltage	-	$V_{CC}$	1.65	-	5.5	V
Quiescent Logic Supply Current	Inputs=0 or $V_{CC}$	$I_{CC}$	-	-	1	$\mu A$
$V_{PWR}$ Voltage	-	$V_{PWR}$	6	-	60	V
$V_{PWR}$ Current	Total of all Outputs	$I_{PWR}$	-	-	240	mA
GND Current	Total of all Outputs	-	-	-	240	mA
Quiescent $V_{PWR}$ Current	$V_{PWR}=42V$ , No Load	-	-	350	-	$\mu A$
High Level Input Voltage	SDA, SCL, OE	$V_{IH}$	$0.7V_{CC}$	-	-	V
Low Level Input Voltage	-	$V_{IL}$	-	-	$0.3V_{CC}$	V
Input Leakage Current	-	-	-	-	1	$\mu A$
Input Hysteresis Voltage	-	-	$0.1V_{CC}$	-	-	V
Output Low Voltage, 3mA Sink	SDA, $V_{CC}>2V$	-	-	-	0.4	V
	$V_{CC}<2V$	-	-	-	$0.2V_{CC}$	
OUT0-OUT15 Current	Any One Output, Sink or Source	-	-	-	15	mA
OUT0-OUT15 On-Resistance	$V_{PWR}=42V$	-	-	45	-	$\Omega$
OUT0-OUT15 Tri-State Leakage	OE=Logic Low	-	-	-	1	$\mu A$

**Notes:** To avoid unwanted output during  $V_{PWR}$  application and system initialization, either reset the device (RSTN logic low) or keep OE at a logic low until the registers are initialized by I<sup>2</sup>C control.

### 1.5 Thermal Characteristics

Parameter	Symbol	Minimum	Typical	Maximum	Unit
Thermal Resistance, Junction-to-Ambient	$R_{\theta JA}$	-	110	-	°C/W

Thermal Resistance is measured in still air with the device soldered to a 6 in<sup>2</sup> board without a ground plane. Applications may require derating of the specified maximum currents to avoid exceeding the maximum operation junction temperature.

### 1.6 AC Electrical Characteristics

$V_{CC}=5V$ ,  $V_{PWR}=42V$ ,  $T_A=25^\circ C$ , unless otherwise specified.

Parameter	Conditions	Min	Typ	Max	Units
OUTx Rise Time	From 10% to 90%, C(OUTx)=200pF	-	170	-	ns
OUTx Fall Time	From 10% to 90%, C(OUTx)=200pF	-	140	-	
OE Rising to OUTx Rising	To 90%	-	1100	-	
OE Rising to OUTx Falling	To 90%	-	600	-	
OE Falling to OUTx High Z	To 10%, OUTx High	-	900	-	
	To 10%, OUTx Low	-	900	-	

## 2 Functional Description

The MX8771 responds to two different slave addresses. The first address can be set from 20h to 27h by connecting pins A2, A1, A0 according to the table below and is used to write and read from the 16-bit data register. The second address is fixed at 28h and facilitates the simultaneous update of outputs from multiple bytes and multiple MX8771's. The contents of the data register are transferred to the

buffer register when the I<sup>2</sup>C master issues a read command to address 28h. The data byte that is read from 28h is a dummy byte whose value is undefined. Optionally the master can terminate the read command after issuing the address and the read bit without actually reading a byte.

A2	A1	A0	I <sup>2</sup> C Slave Address (hex)
0	0	0	20
0	0	1	21
0	1	0	22
0	1	1	23
1	0	0	24
1	0	1	25
1	1	0	26
1	1	1	27

RSTN	OE	All Outputs
0	0	High-Z
1	0	High-Z
0	1	GND
1	1	I <sup>2</sup> C Control

For the following timing examples, pin A2 = high, A1 = high, A0 = low

Write two bytes to the MX8771 data register and then update the MX8771 buffer register:

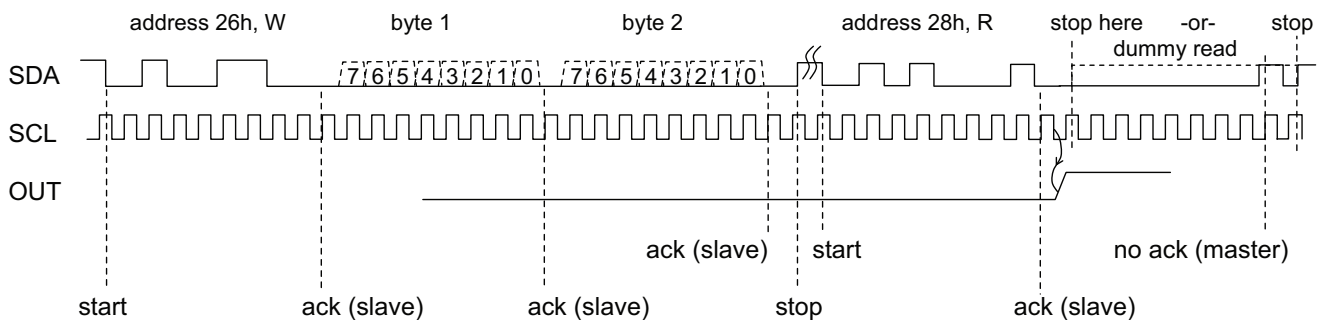

Read two bytes from the MX8771 data register:

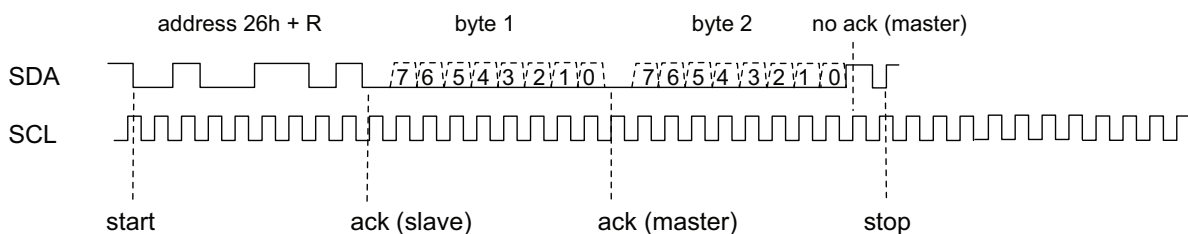

### 3 Manufacturing Information

#### 3.1 Mechanical Dimensions

##### 3.1.1 8-Pin DIP Through-Hole Package

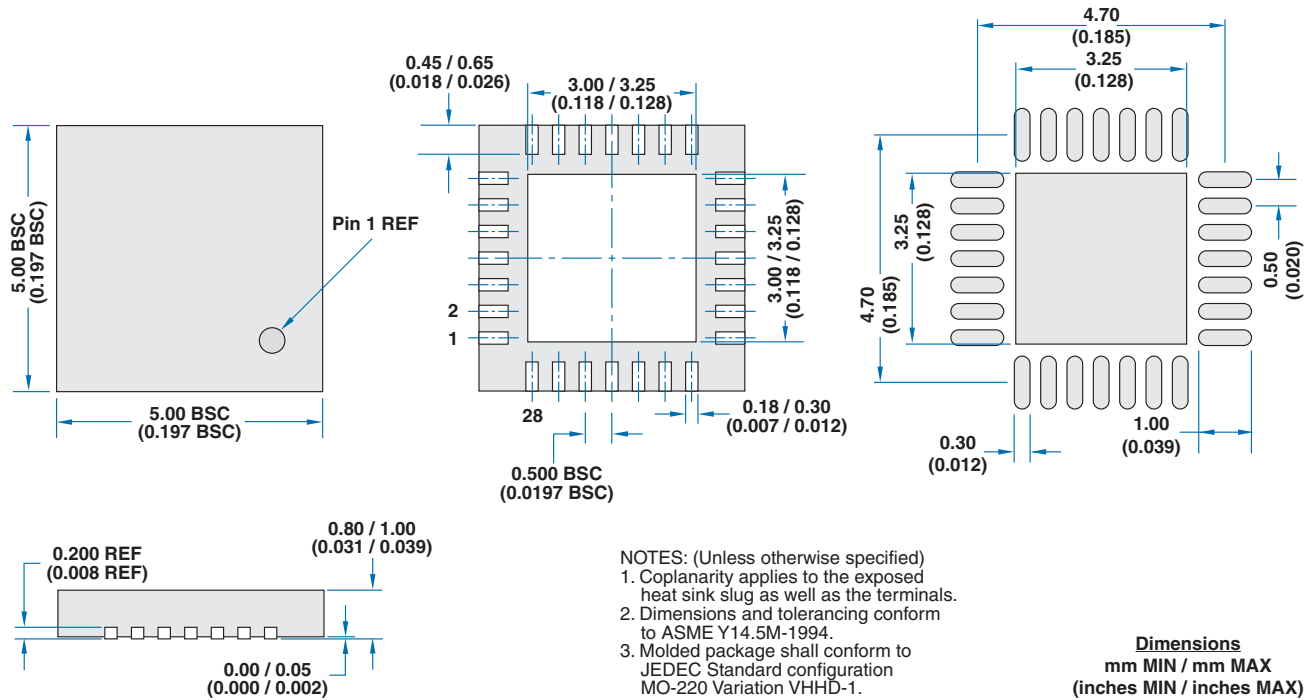

##### 3.1.2 Tape & Reel

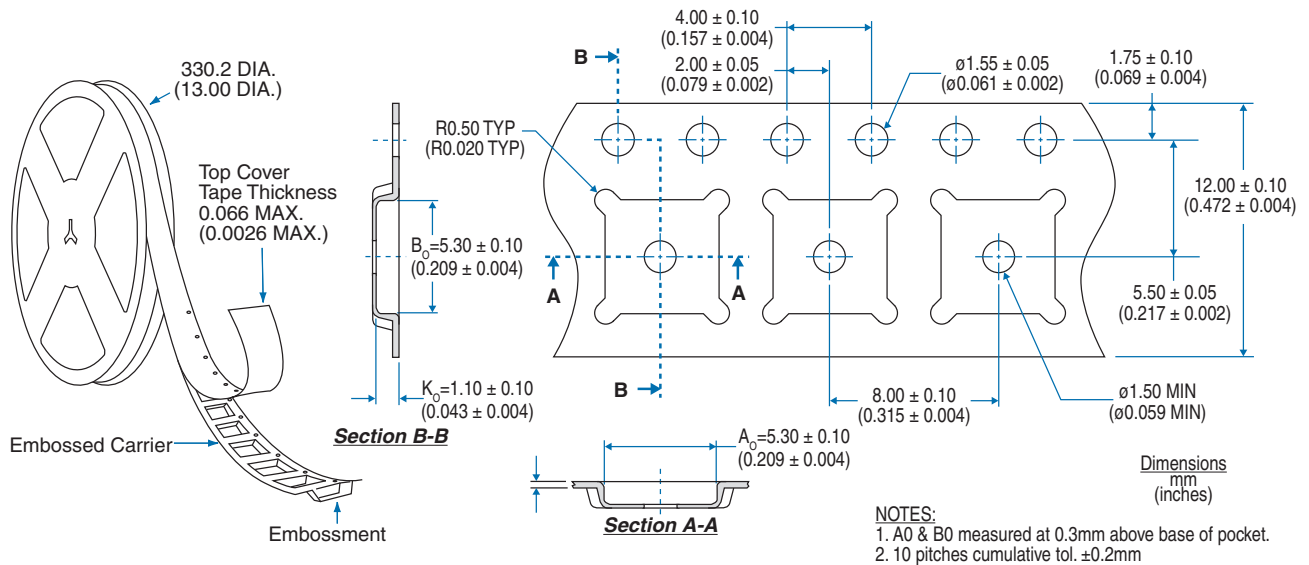

**3.2 Soldering**

For proper assembly, the component must be processed in accordance with the current revision of IPC/JEDEC standard J-STD-020. Failure to follow the recommended guidelines may cause permanent damage to the device resulting in impaired performance and/or a reduced lifetime expectancy.

**3.3 Washing**

Clare does not recommend ultrasonic cleaning or the use of chlorinated hydrocarbons.



**For additional information please visit our website at: [www.clare.com](http://www.clare.com)**

Clare, Inc. makes no representations or warranties with respect to the accuracy or completeness of the contents of this publication and reserves the right to make changes to specifications and product descriptions at any time without notice. Neither circuit patent licenses nor indemnity are expressed or implied. Except as set forth in Clare's Standard Terms and Conditions of Sale, Clare, Inc. assumes no liability whatsoever, and disclaims any express or implied warranty, relating to its products including, but not limited to, the implied warranty of merchantability, fitness for a particular purpose, or infringement of any intellectual property right.

The products described in this document are not designed, intended, authorized or warranted for use as components in systems intended for surgical implant into the body, or in other applications intended to support or sustain life, or where malfunction of Clare's product may result in direct physical harm, injury, or death to a person or severe property or environmental damage. Clare, Inc. reserves the right to discontinue or make changes to its products at any time without notice.

Specification: DS-MX8771-R00B  
©Copyright 2009, Clare, Inc.  
All rights reserved. Printed in USA.  
12/18/09