

Features

- Full Bridge Gate Driver
- Internal high voltage level shift function
- Negative 550V Lamp Supply Voltage
- 3V to 12V CMOS Logic Compatible
- External Dead Time Control
- 8V to 12V Input Supply Voltage
- No External Bootstrap Capacitors

Ordering Information

Part No.	Description	Qty
MX6895BE	SOIC-16 Tube	49
MX6895BETR	SOIC-16 Tape & Reel	2500

General Description

The MX6895 features our high voltage integrated circuit (HVIC) technology integrating high and low side N-channel power MOSFET drivers in a full bridge configuration. The circuit is intended as a commutator for High Intensity Discharge (HID) lamps.

Applications

- Commutator for High Intensity Discharge Lamps
 - Vehicle Head Lamps
 - Outdoor/Street Lighting
 - Multimedia Projectors
 - Retail Accent Lighting
 - Warehouse Lighting

Functional Block Diagram and Typical Application Circuit

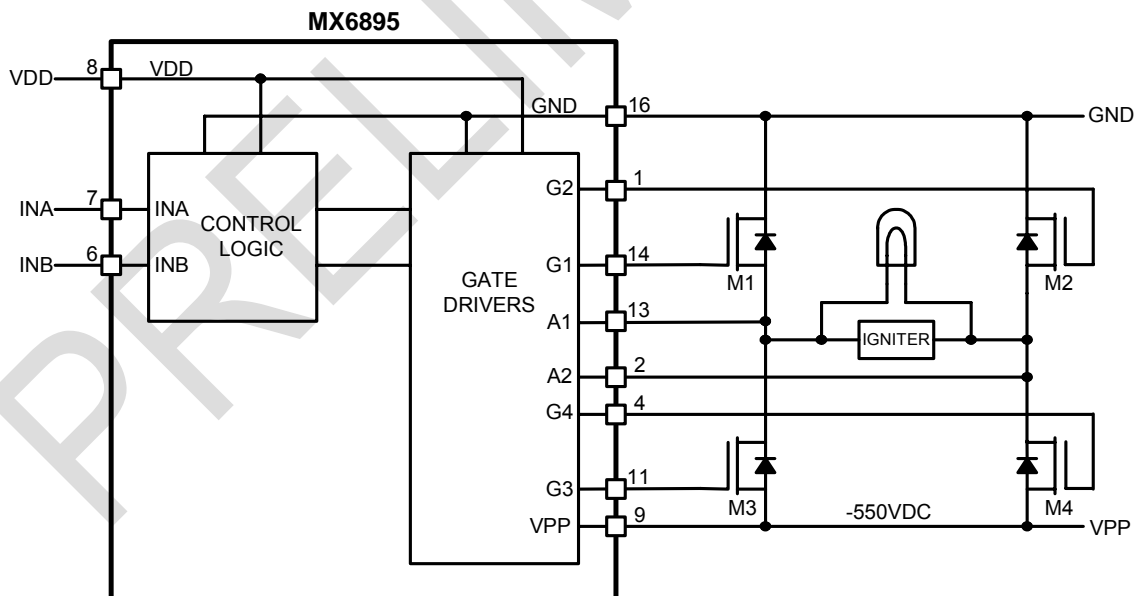

Absolute Maximum Ratings (Voltages with respect to GND=0V)

Parameter	Symbol	Min	Max	Unit
Power Supply Voltage	VDD	-0.3	15	V
Lamp Supply Voltage	VPP		-600	V
Input Voltage	VINA, VINB	-0.3	VDD+0.3V	V
Gate Driver Output Voltage	(VG1-VA1) (VG2-VA2) (VG3-VPP) (VG4-VPP)	-0.3	20	V
Power Dissipation	PTOT		1	W
Storage Temperature	TSTG	-50	150	C°
Operating Junction Temp	TJ		150	C°
Thermal Resistance (Junction to Ambient)	RθJA	42 Typical (NOTE 1)		C°/W
Input Capacitance of external Power Transistors	CISS(LOAD)	0.4	1.5	nF

Absolute Maximum Ratings are stress ratings. Stresses in excess of these ratings can cause permanent damage to the device. Functional operation of the device at these or any other conditions beyond those indicated in the operational sections of this data sheet is not implied. Exposure of the device to the absolute maximum ratings for an extended period may degrade the device and affect its reliability.

Note 1: 4 layer PCB

Pin Description

Pin No.	Pin Name	Description
1	G2	High Side Gate Driver 2 Output
2	A2	High Side Gate Driver 2 Floating DC Power Return
3	NC	No Connect
4	G4	Low Side Gate Driver 4 Output
5	NC	No Connect
6	INB	Control Input for High Side Driver 2 and Low Side Driver 3
7	INA	Control Input for High Side Driver 1 and Low Side Driver 4
8	VDD	Logic Power Supply
9	VPP	High Voltage Negative Lamp Supply
10	NC	No Connect
11	G3	Low Side Gate Driver 3 Output
12	NC	No Connect
13	A1	High Side Gate Driver 1 Floating DC Power Return
14	G1	High Side Gate Driver 1 Output
15	NC	No Connect
16	GND	Ground

NOTE: The Exposed Thermal Pad of the device package must be connected to Ground.

ESD Warning

ESD (electrostatic discharge) sensitive device. Although the MX6895 features proprietary ESD protection circuitry, permanent damage may be sustained if subjected to high energy electrostatic discharges. Proper ESD precautions are recommended to avoid performance degradation or loss of functionality.

Operating Range (Voltages with respect to GND=0V)

Parameter	Symbol	Min	Typ	Max	Unit
Power Supply Voltage	VDD	8	10	12	V
Lamp Supply Voltage	VPP	-50	-	-550	V
Logic Input Voltage High	VINAH, VINBH	2.5	VDD	VDD	V
Logic Input Voltage Low	VINAL, VINBL	0	0	0.5	V
Ambient Temperature	TA	-40	-	105	C°

DC Electrical Characteristics

TA=25°C, unless otherwise specified.

Parameter	Symbol	Condition	Min	Typ	Max	Unit
Power Supply Current	IDD	VDD = 10V, VPP = -85V VINA = VDD, VINB = VDD		1	2	mA
Power Supply Current	IPP	VDD = 10V, VPP = -85V VINA = VDD, VINB = VDD		0.8	2	mA
Power Supply Current	IDD	VDD = 10V, VPP = -85V VINA = 2.5V, VINB = 2.5V		1.5	4	mA
High Input Current	IINAH IINBH	VINAH = 10V VINBH = 10V			10	μA
Low Input Current	IINAL IINBL	VINAL = 0V VINBL = 0V			10	μA
High Side Gate Driver Output Voltage	(VG1-VA1) (VG2-VA2)	VDD = 8V, VPP = -85V VA1, VA2 = 0V	7.0		8.0	V
High Side Gate Driver Output Voltage	(VG1-VA1) (VG2-VA2)	VDD = 10V, VPP = -85V VA1, VA2 = 0V	9.0		10.0	V
Low Side Gate Driver Output Voltage	(VG3-VPP) (VG4-VPP)	VDD = 8V to 10V VPP = -85V	7.0	15.0	18.0	V
High Side Gate Driver Output Source Current	(IG1, IG2)	VDD = 10V, VPP = -85V VA1, VA2 = 0V VG1 - VA1 = 0V VG2 - VA2 = 0V		4.5		mA
Low Side Gate Driver Output Source Current	(IG3, IG4)	VDD = 8V to 10V VPP = -85V VG3-VPP = 0V VG4-VPP = 0V		15.0		mA

AC Electrical Characteristics

VDD = 10V, VPP = -85V, VA1 = VA2 = 0V, TA=25°C, unless otherwise specified.

Parameter	Symbol	Condition	Min	Typ	Max	Unit
Operating Frequency	fOP			0.5		KHz
High Side ON Time @ VOUT=5V	tonH	CLOAD = 1.0nF		2.7		μS
High Side OFF Time @ VOUT=2V	toffH	CLOAD = 1.0nF		0.4		μS
Low Side ON Time @ VOUT=5V	tonL	CLOAD = 1.0nF		1.0		μS
Low Side OFF Time @ VOUT=2V	toffL	CLOAD = 1.0nF		0.3		μS

Notes: 1. VOUT is the voltage on CLOAD at the defined time.
 2. VOUT = VG1-VA1, or VOUT = VG2-VA2, or VOUT = VG3-VPP, or VOUT = VG4-VPP

AC Test Circuit

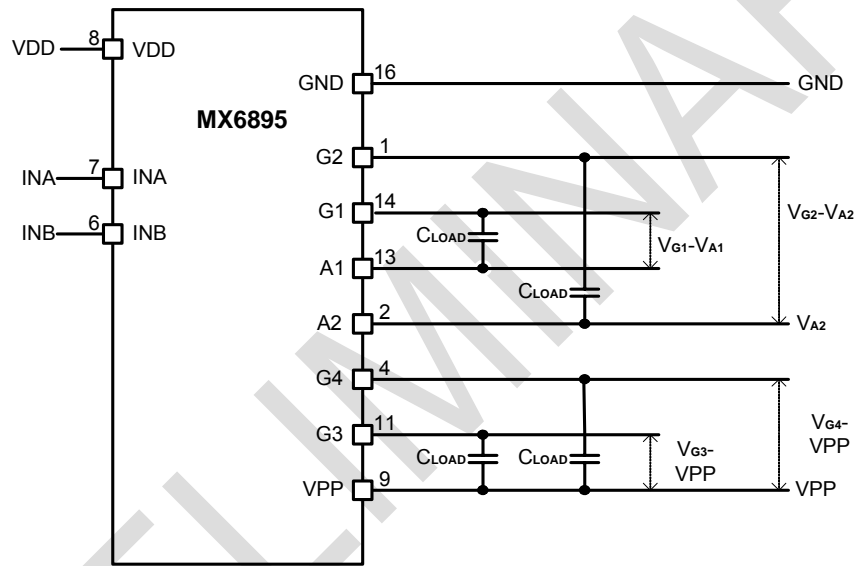

AC Switching Waveforms

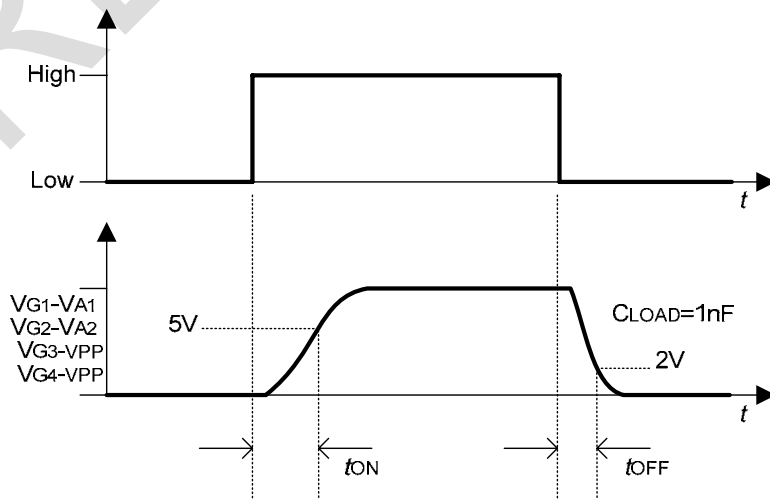

Function Block Diagram

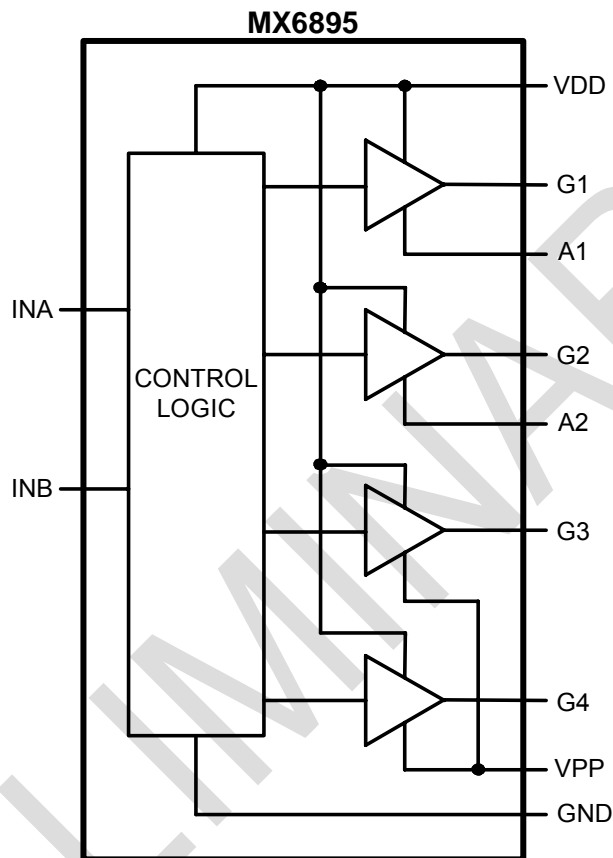

Function Table

INA	INB	G1 - A1	G2- A2	G3 - VP	G4 - VPP
LOW	LOW	LOW	LOW	LOW	LOW
HIGH	LOW	HIGH	LOW	LOW	HIGH
LOW	HIGH	LOW	HIGH	HIGH	LOW
HIGH	HIGH	LOW	LOW	LOW	LOW

Input / Output Switching Waveforms

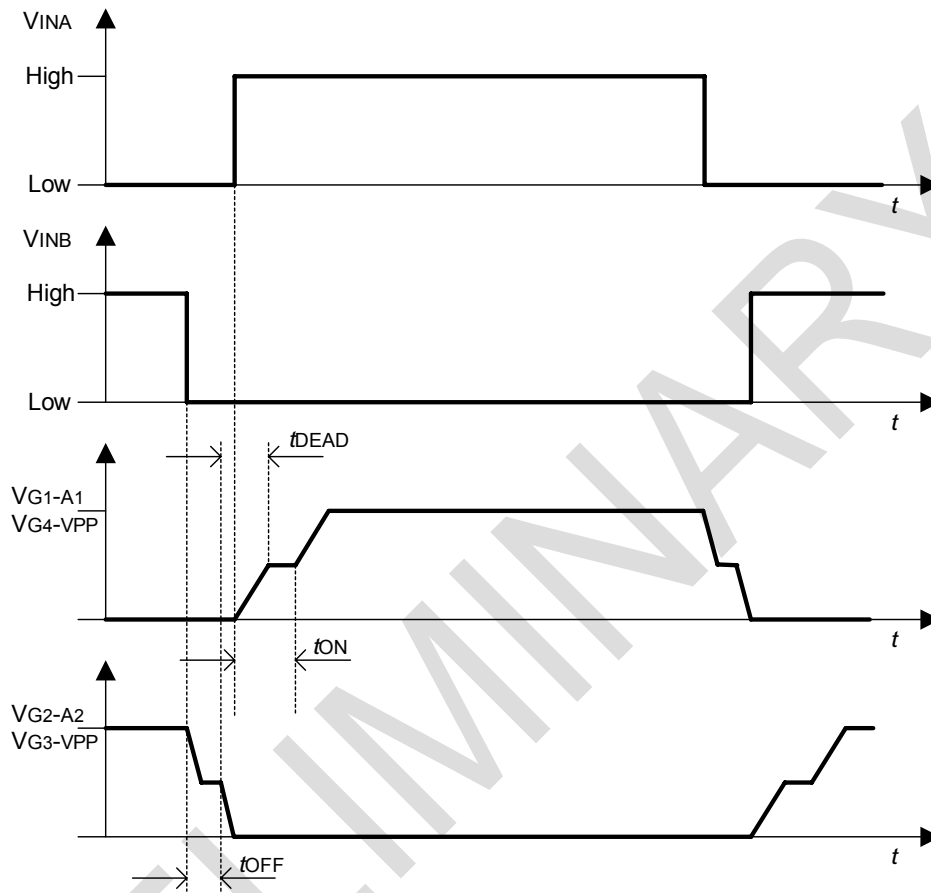

IXYS Corporation

3540 Bassett Street
Santa Clara, CA 925054
Tel: 1-408-982-0700
Fax: 1-408-496-0670
e-mail:sales@ixys.net

Micronix**An IXYS Company**

145 Columbia
Aliso Viejo, CA 92656-1490
Tel: 1-949-831-4622
Fax: 1-949-831-4628

SALES OFFICES AMERICAS**Eastern Region**

[Eastern North America, Mexico, South America]
IXYS Corporation
Beverly, MA
Tel: 508-528-6883
Fax: 508-528-4562
wgh@ixys.net

Central Region

[Central North America]
IXYS Corporation
Greensburg, PA
Tel: 724-836-8530
Fax: 724-836-8540
neil.lejeune@westcode.com

Western Region

[Western North America]
IXYS Corporation
Solana Beach, CA
Tel: 858-792-1101
slodor@ix.netcom.com

SALES OFFICES EUROPE**European Headquarters**

IXYS Semiconductor GMBH
Edisonstrasse 15
D- 68623 Lampfertheim
Germany
Tel : 49-6206-503203
Fax: 49-6206-503286
marcom@ixys.de

United Kingdom

IXYS Semiconductor Limited
Langley Park Way
Langley Park
Chippenham
Wiltshire SN 15 1GE - England
Tel: 44-1249-444524
Fax: 44-1249-659448
sales@ixys.co.uk

SALES OFFICES ASIA / PACIFIC**Asian Headquarters**

IXYS
Room 1016, Chia-Hsin, Bldg II,
10F, No. 96, Sec. 2
Chung Shan North Road
Taipei, Taiwan R.O.C.
Tel: 886-2-2523-6368
Fax: 886-2-2523-6368
bradley.green@ixys.co.uk
Jhong@clare.com

<http://www.claremicronix.com>

IXYS cannot assume responsibility for use of any circuitry other than circuitry entirely embodied in this IXYS product. No circuit patent licenses nor indemnity are expressed or implied. IXYS reserves the right to change the specification and circuitry, without notice at any time. The products described in this document are not intended for use in medical implantation or other direct life support applications where malfunction may result in direct physical harm, injury or death to a person.

Specification: MX6895
©Copyright 2007, IXYS Corporation
All rights reserved. Printed in USA.