

Features

- Meets wetting (sealing) current requirements per ITU-T G.991.2
- Integrated bridge rectifier for polarity correction
- Uses inexpensive opto-coupler for DC sealing current monitoring
- Electronic inductor, breakover, and latch circuits
- Current limiting and excess power protection circuits
- ADSL/VDSL compatible with low-pass filter network
- MLT and SARTS compatible
- Compatible with portable test sets
- Small SOIC or Micro-Leadframe Package (MLP)
- MLP package 60 percent smaller than SOIC

Applications

- ADSL/VDSL broadband modems
- Router and bridge customer premises equipment
- Leased line equipment
- Mechanized Loop Test (MLT) networks
- Switched Access Remote Test System (SARTS) networks

Description

The CPC1466 is a DC Termination IC for broadband ADSL/VDSL applications. The high-voltage, monolithic device provides a path for DC wetting (sealing) current in customer premises equipment (CPE) to eliminate phone line corrosion on DSL twisted-pair copper lines without telephone voice services (i.e. only broadband services).

Internally, a bridge rectifier provides a polarity-insensitive DC termination for DSL loop sealing current. The IC includes an electronic inductor, break-over and latch circuits, current limit and excess power protection. A sealing current detect output provides the means to monitor the loop for the presence of sealing current in the loop.

The CPC1466 is manufactured in Clare's high voltage BCDMOS process that is used extensively in telephony applications worldwide.

Ordering Information

Part Number	Description
CPC1466D	DC Termination IC, 16-pin SOIC in tubes, 47/tube
CPC1466DTR	DC Termination IC, 16-pin SOIC tape and reel, 1000/reel
CPC1466M	DC Termination IC, 16-pin MLP in tubes, 52/tube
CPC1466MTR	DC Termination IC, 16-pin MLP tape and reel, 1000/reel

Figure 1. CPC1466 Block Diagram

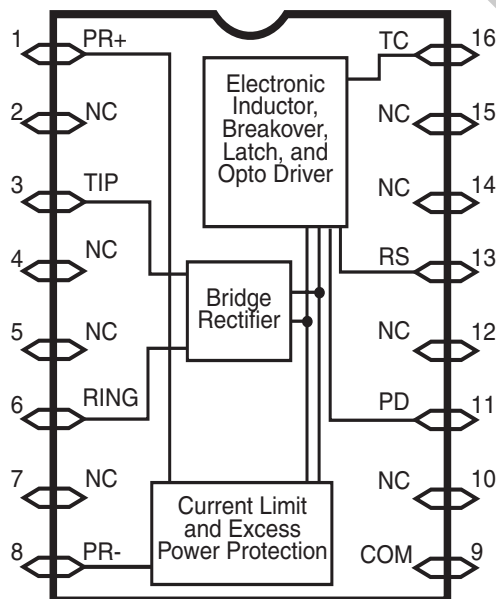

1. Specifications 3

1.1 Package Pinout 3

1.2 Pin Description 3

1.3 Absolute Maximum Ratings 3

1.4 Electrical Characteristics 4

 1.4.1 DC Characteristics, Normal Operation 4

 1.4.2 AC Characteristics, Normal Operation 4

 1.4.3 Transition Characteristics, Normal Operation 4

1.5 Sealing Current Monitor Characteristics 8

 1.5.1 LED Trigger Characteristics 8

2. Functional Description 10

2.1 Introduction 10

2.2 Surge Protection 10

2.3 Bridge Rectifier 10

2.4 State Transitions 10

 2.4.1 Activation - On-State 10

 2.4.2 Deactivation - Off-State 10

2.5 Photo-Diode (PD) Output Behavior 10

2.6 On-State Behavior 11

 2.6.1 Typical Conditions 11

 2.6.2 Over-Voltage Conditions 11

3. Manufacturing Information 12

3.1 Mechanical Dimensions 12

 3.1.1 SOIC 12

 3.1.2 MLP 13

3.2 Printed Circuit Board Layout Pattern 14

 3.2.1 SOIC 14

 3.2.2 MLP 14

3.3 Tape and Reel Packaging 14

 3.3.1 SOIC 14

 3.3.2 MLP 15

3.4 Soldering 15

 3.4.1 Moisture Reflow Sensitivity 15

 3.4.2 Reflow Profile 15

3.5 Washing 15

PRELIMINARY

1. Specifications

1.1 Package Pinout

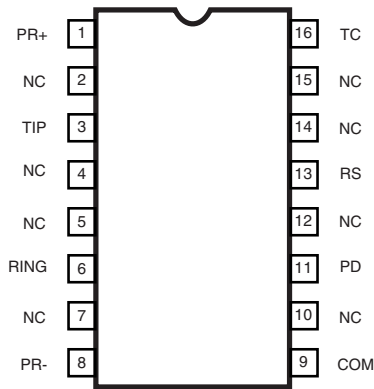

1.2 Pin Description

Pin	Name	Description
1	PR+	Protection resistor positive side
2	NC	No connection
3	TIP	Tip Lead
4	NC	No connection
5	NC	No connection
6	RING	Ring lead
7	NC	No connection
8	PR-	Protection resistor negative side
9	COM	Common
10	NC	No connection
11	PD	Photo-diode (LED input current)
12	NC	No connection
13	RS	Current limiting resistor
14	NC	No connection
15	NC	No connection
16	TC	Timing capacitor

1.3 Absolute Maximum Ratings

Parameter	Minimum	Maximum	Unit
Maximum Voltage (T to R, R to T)*	-	300	V
Power dissipation	-	1	W
Operating temperature	-40	+85	°C
Operating relative humidity	5	95	%
Storage temperature	-40	+125	°C

Electrical absolute maximum ratings are at 25°C.

Absolute maximum ratings are stress ratings. Stresses in excess of these ratings can cause permanent damage to the device. Functional operation of the device at conditions beyond those indicated in the operational sections of this data sheet is not implied.

1.4 Electrical Characteristics

Unless otherwise specified, minimum and maximum values are guaranteed by production testing requirements. Typical values are characteristic of the device and are the result of engineering evaluations. In addition, typical values are provided for

informational purposes only and are not part of the testing requirements.

All electrical specifications are provided for $T_A=25^\circ\text{C}$

1.4.1 DC Characteristics, Normal Operation

For operational templates: (see Figure 2 on page 5) and (see Figure 3 on page 5).

Parameter	Conditions	Symbol	Minimum	Typical	Maximum	Unit
Activate/Non-activate Voltage	Off State	V_{AN}	30.0	35.0	39.0	V
Breakover current	-	I_{BO}	-	0.5	1	mA
DC Voltage drop	Active State, $1\text{ mA} \leq I_{SL} \leq 20\text{ mA}$	V_{ON}	-	12.5	15	V
DC leakage current	$V_{OFF} = 20\text{ V}$	I_{LKG}	-	1.5	5	μA
Hold/Release current	Active State	$I_{H/R}$	0.1	0.5	1.0	mA
Minimum on current	$V_{ON} < 54\text{ V}$	I_{MIN1}	20	38	-	mA
	$54\text{ V} \leq V_{ON} \leq 100\text{ V}$ for 2 seconds, source resistance $200\ \Omega$ to $4\text{ k}\Omega$	I_{MIN2}	9.0	45	-	mA
	$V_{ON} > 100\text{ V}$	I_{MIN3}	0	0.1	-	mA
Maximum on current	$V_{ON} \leq 70\text{ V}$	I_{MAX1}	-	38.4	70	mA
	$V_{ON} > 70\text{ V}$	I_{MAX2}	-	-	$\frac{V_{ON}}{1\text{ k}\Omega}$	mA
Photodiode drive current	Active State	I_{PD}	0.2	0.3	10	mA

1.4.2 AC Characteristics, Normal Operation

For test conditions: (see Figure 4 on page 6).

Parameter	Conditions	Symbol	Minimum	Typical	Maximum	Unit
AC impedance	200 Hz to 50 kHz	Z_{MT}	10	38	-	$\text{k}\Omega$
Linearity distortion	$f = 200\text{ Hz to }40\text{ kHz}$, $I_{SL} = 1\text{ mA to }20\text{ mA}$, $V_{APP} \leq 12\text{ V}_{PP}$	D	40	70	-	dB

1.4.3 Transition Characteristics, Normal Operation

For activation/deactivation test conditions: (see Figure 5 on page 7).

Parameter	Conditions	Symbol	Minimum	Typical	Maximum	Unit
Activate time	(see Figure 6 on page 7)	t_1	3.0	13	50	ms
Deactivate time	(see Figure 7 on page 7)	t_2	3.0	-	100	ms

Figure 2. I-V Requirements Template, 0 V to 50 V

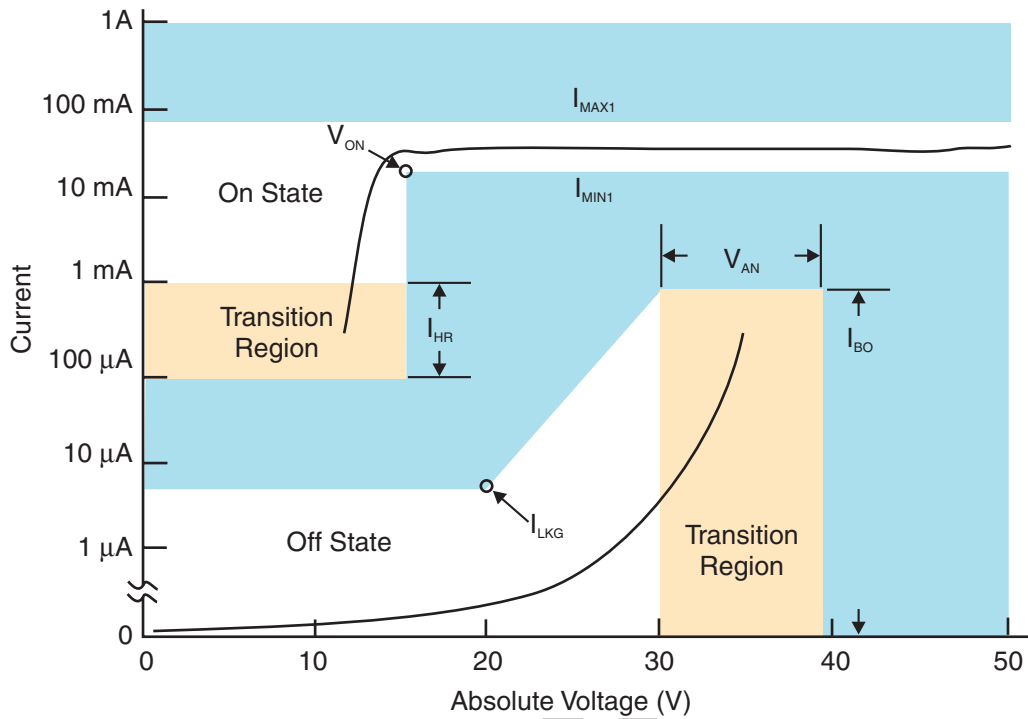

Figure 3. I-V Requirements Template, 0 V to 250 V

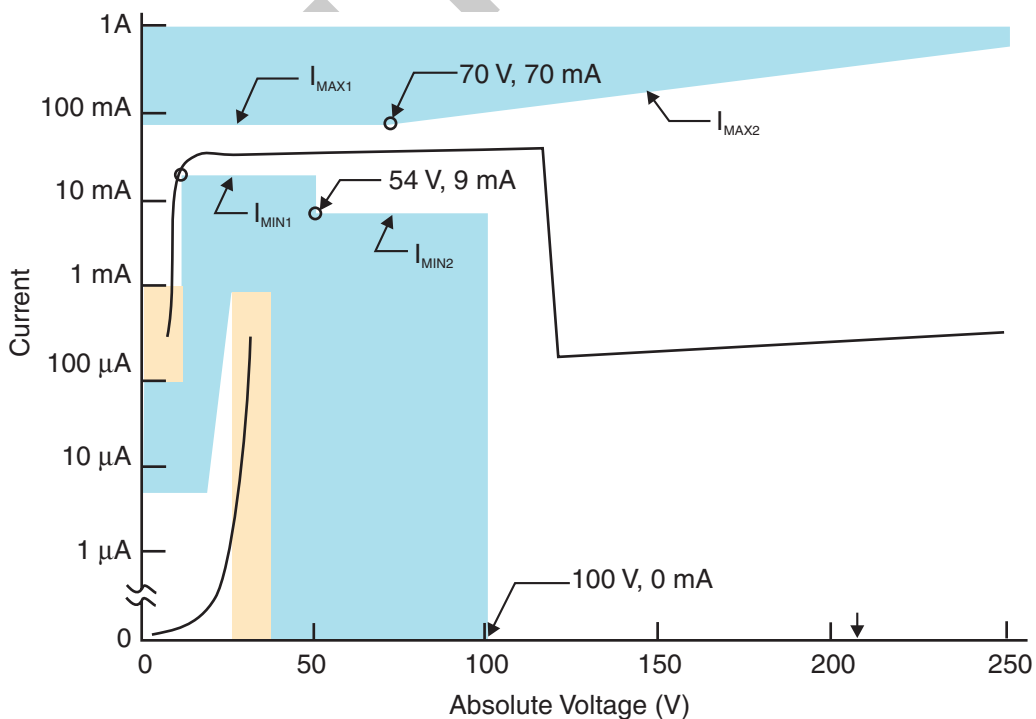
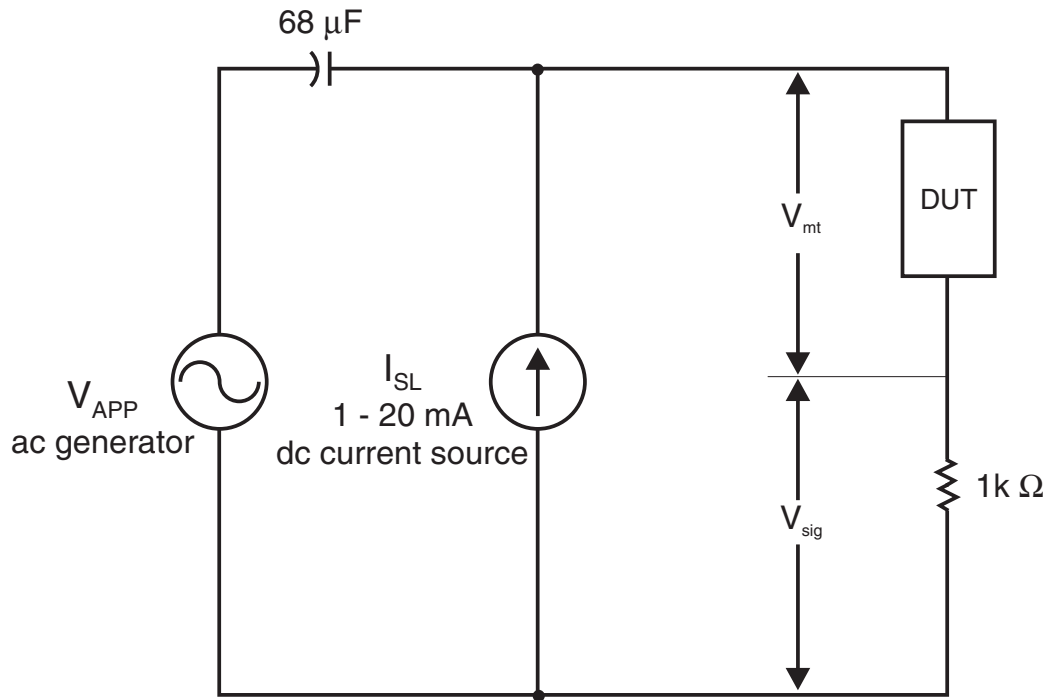

Figure 4. Test Circuit for ac Impedance and Linearity



$$Z_{mt} = \frac{1000 \times V_{mt}}{V_{sig}}$$

$$\text{Linearity} = 20 \log \left[\frac{V_{mt}}{V_{sig2ndHarmonic}} \right] + 20 \log \left[\frac{1000}{67.5} \right]$$

PRELIMINARY

Figure 5. Test Circuit for Activate and Deactivate Times

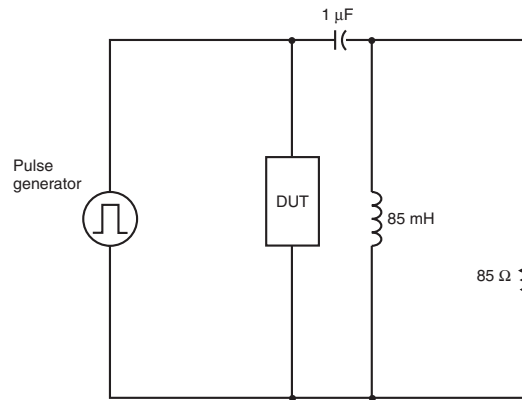

Figure 6. Applied Waveform for Activation Test

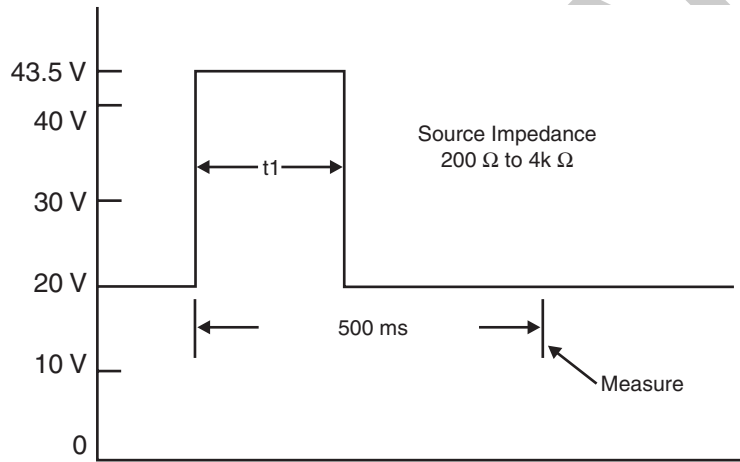
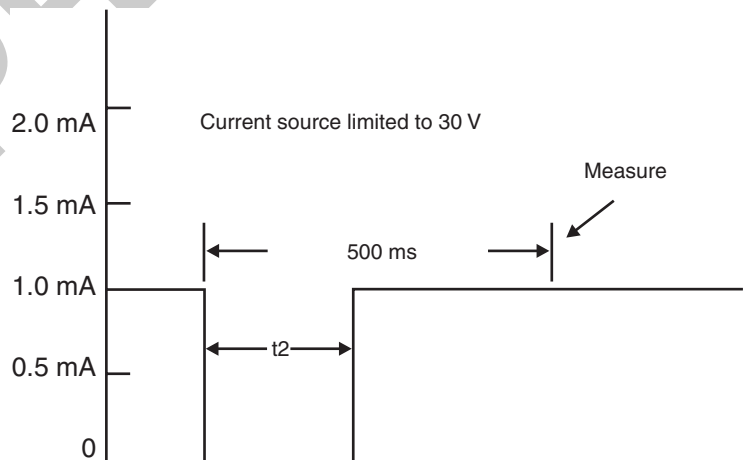

Figure 7. Applied Waveform for Deactivation Test



1.5 Sealing Current Monitor Characteristics

1.5.1 LED Trigger Characteristics

For test conditions: (see Figure 8 on page 8).

Parameter	Conditions	Symbol	Minimum	Typical	Maximum	Unit
Applied dc battery Voltage	-	-	-43.5	-	-56	V _{DC}
Frequency (pulses per second)	-	-	4	-	8	-
Percent break	-	-	40	-	60	%
Number of pulses	-	-	6	-	10	-
Total Loop Resistance	-	-	200	-	4000	Ω
Required opto-coupler response						
Number of applied pulses per make/break	-	-	-	1	-	-
Pulse width (opto on)	(see Figure 8 on page 8)	T _{ON}	10	-	-	ms
Pulse width (opto off)	(see Figure 8 on page 8)	T _{OFF}	10	-	-	ms

Figure 8. Test Circuit for LED Operation

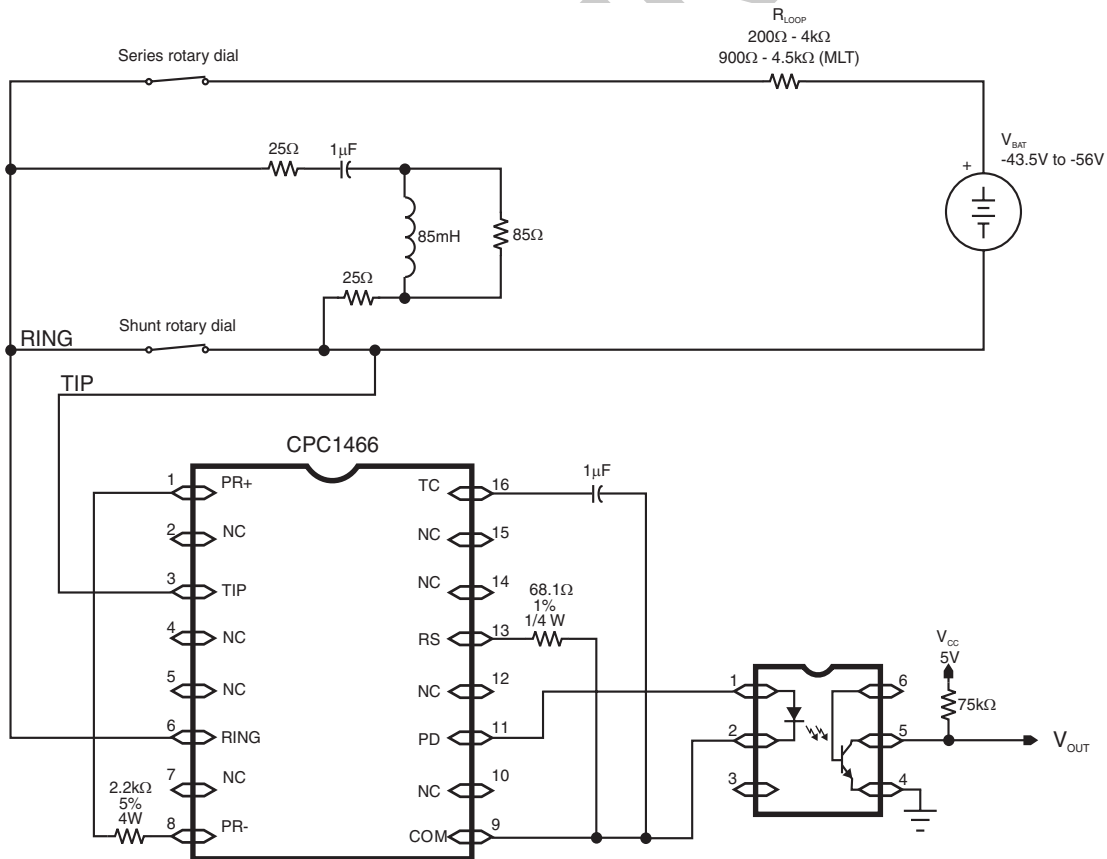

2. Functional Description

2.1 Introduction

The CPC1466 can be used for a number of DSL designs requiring a dc hold circuit such as ADSL modem applications. Typical ADSL applications will use a filter circuit design similar to the one shown in Figure 9, "Typical ADSL/VDSL Application Diagram" on page 9.

The DC Termination IC performs two fundamental functions in an ADSL modem application; as an electronic inductor providing a low impedance dc termination with a high impedance ac termination and second as part of the sealing current detection system for automated line sensing. This function provides an excellent method to monitor for the presence of sealing current. Generally, loss of sealing current indicates loop loss.

As can be seen in the application circuit in Figure 9 on page 9, CPC1466 designs require few external components. For the CPC1466, all that is needed is a circuit protector, two resistors and a capacitor. To ensure DSL signal integrity over a wide variety of conditions a POTS splitter type filter is recommended to isolate the DSL traffic from the termination.

2.2 Surge Protection

Although the CPC1466 self protects via current limiting, it requires over-voltage surge protection to protect against destructive over-voltage transients. Clare recommends the use of a crowbar-type surge protector to limit the surge voltage seen by the CPC1466 to less than 250 V. The protection device must be able to withstand the surge requirements specified by the appropriate governing agency in regions where the product will be deployed. Teccor, Inc. and Bourns, Inc. make suitable surge protectors for most applications. Devices such as Teccor's P1800SD or P2000SD Sidactors and Bourns' TISP4220H3BJ or TISP4240H3BJ thyristors should provide suitable protection.

2.3 Bridge Rectifier

The bridge rectifier in the CPC1466 ensures that the device is polarity insensitive and provides consistent operational characteristics if the tip to ring polarity is reversed.

2.4 State Transitions

The dc tip to ring voltage-current characteristics of the CPC1466 are shown in Figure 2, "I-V Requirements Template, 0 V to 50 V", and in Figure 3, "I-V Requirements Template, 0 V to 250 V" on page 5.

Transition timings are illustrated in Figure 6, "Applied Waveform for Activation Test", and in Figure 7, "Applied Waveform for Deactivation Test". The test configuration for these timings is given in Figure 5, "Test Circuit for Activate and Deactivate Times". All timing figures are located on page 7.

State transition timings are set by the 1 μ F capacitor connected between the TC and COM pins.

2.4.1 Activation - On-State

Application of battery voltage to the loop causes the CPC1466 to conduct whenever the voltage exceeds approximately 35 V. With application of sufficient voltage applied across the tip and ring terminals, the CPC1466 will initially conduct a nominal 150 μ A of sealing current for approximately 20 ms prior to activation. Once activated, the CPC1466 will remain in the on state for as long as the loop current exceeds a nominal 0.5 mA.

The CPC1466 turn-on timing circuit assures device activation will occur within 50 ms of an applied voltage greater than 43.5 V but not within the first 3 ms.

2.4.2 Deactivation - Off-State

While the CPC1466 activation protocol is based on an initial minimum voltage level, deactivation is based on a diminished sealing current level. Deactivation occurs when the nominal sealing current level drops below 0.5 mA with guaranteed deactivation occurring for sealing current levels less than 0.1 mA

The turn-off timing circuit deactivates the sealing current hold circuit when 1 mA of sealing current has been removed for 100 ms but ignores periods of loss up to 3 ms.

2.5 Photo-Diode (PD) Output Behavior

Output from the PD pin provides a minimum of 0.2 mA of photodiode drive current for an optocoupler's LED anytime sealing current exceeds 1 mA.

Because LED current is interrupted whenever loop current is interrupted, the optocoupler provides an

excellent means of indicating loop availability for designs with a full time sealing current requirement. In addition, for pulsed sealing current loops, the status from this detector when used in conjunction with the timing of modem retraining events can be used as an indicator to determine if the sealing current event is clearing line impairments.

2.6 On-State Behavior

2.6.1 Typical Conditions

On-state sealing current levels are determined by the network's power feed circuit and the loop's dc impedance. To compensate for low loop resistance or very high loop voltage, the CPC1466 limits the maximum sealing current to 70 mA.

The CPC1466 manages package power dissipation by shunting excess sealing current through the 2.2 k Ω 4W power resistor located between the PR+ and PR- pins.

2.6.2 Over-Voltage Conditions

Potentials in excess of 100 V applied to the tip and ring interface will cause the CPC1466 to disable the sealing current hold circuit and enter a standby state with very little current draw. Once the over-voltage condition is removed, the CPC1466 automatically resumes normal operation.

PRELIMINARY

3. Manufacturing Information

3.1 Mechanical Dimensions

3.1.1 SOIC

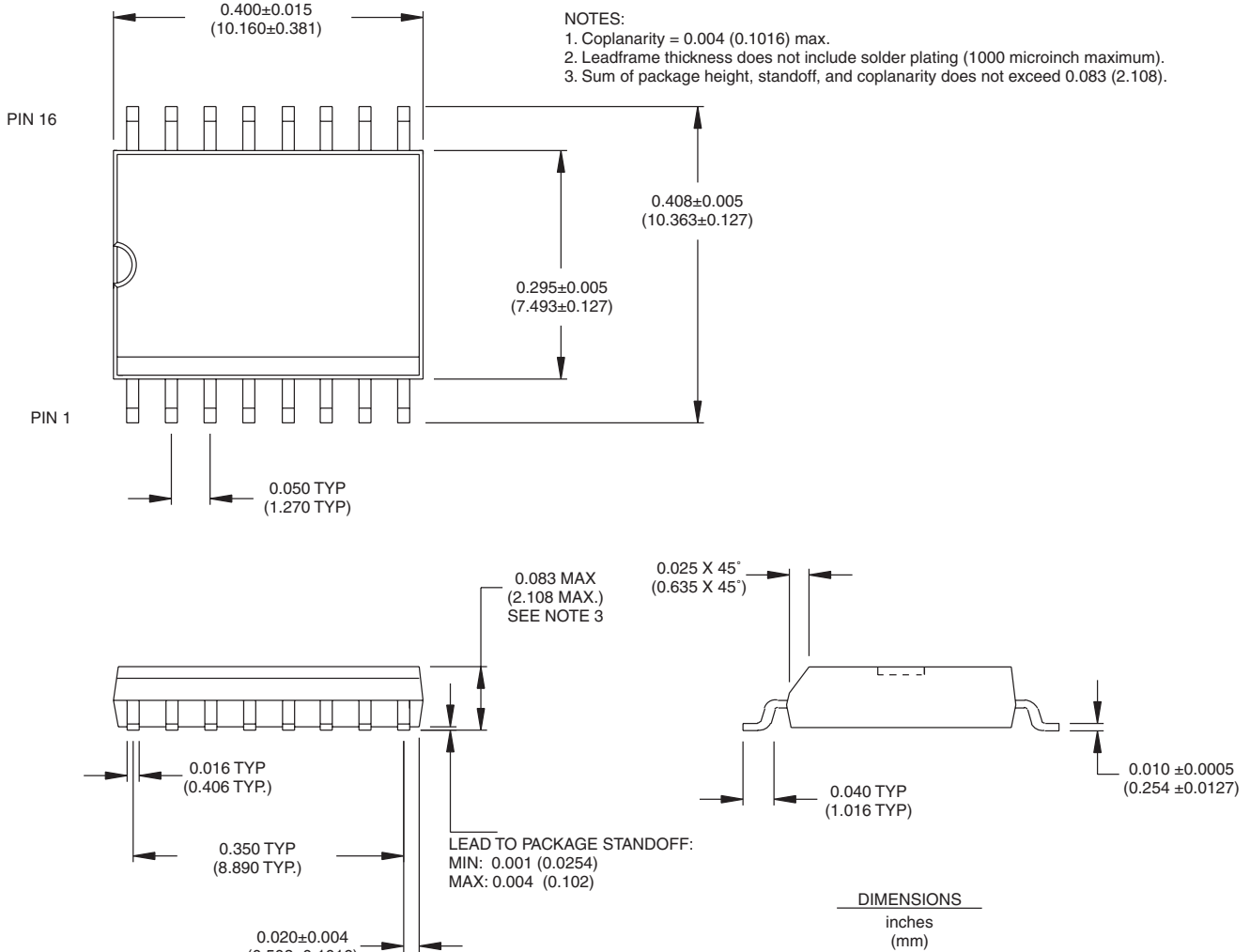

3.1.2 MLP

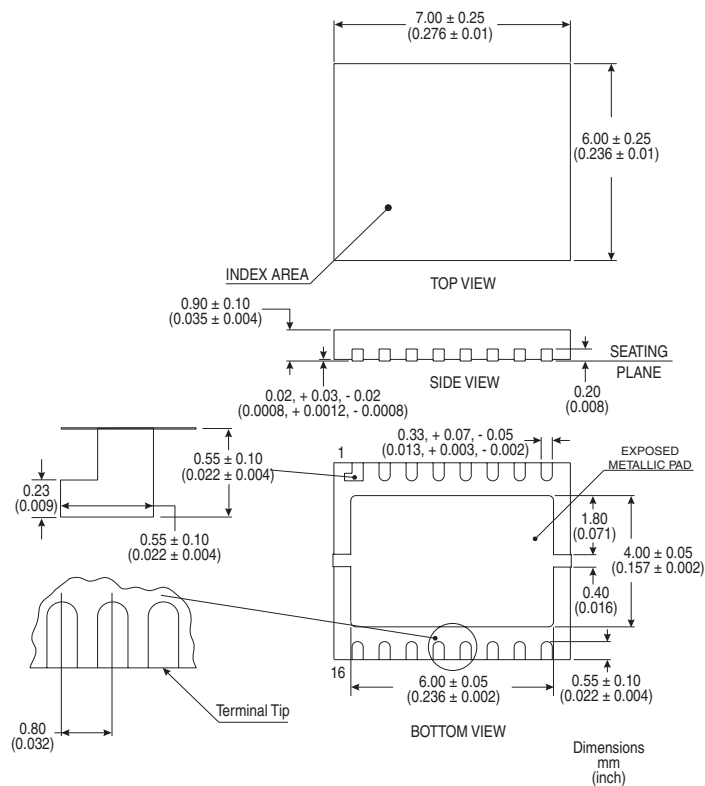

PRELIMINARY

3.2 Printed Circuit Board Layout Pattern

3.2.1 SOIC

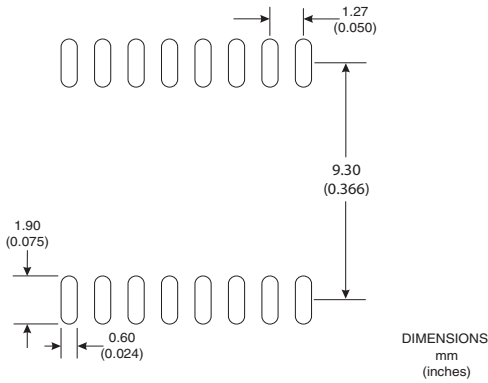

3.2.2 MLP

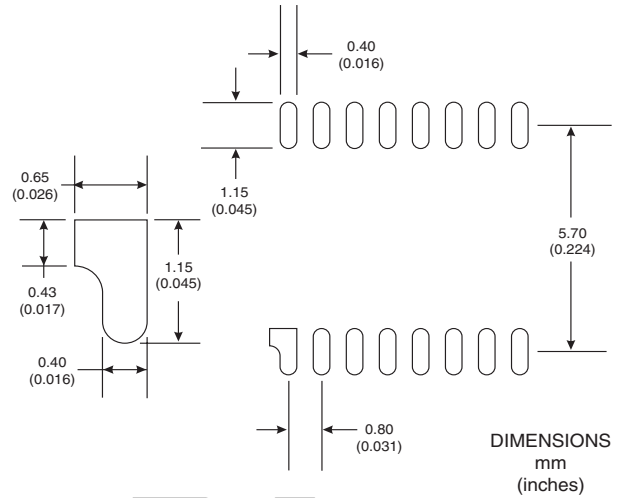

NOTE: As the metallic pad on the bottom of the MLP package is connected to the substrate of the die, Clare recommends that no printed circuit board traces or vias be placed under this area.

3.3 Tape and Reel Packaging

3.3.1 SOIC

Tape and Reel Packaging for 16-Pin SOIC Package

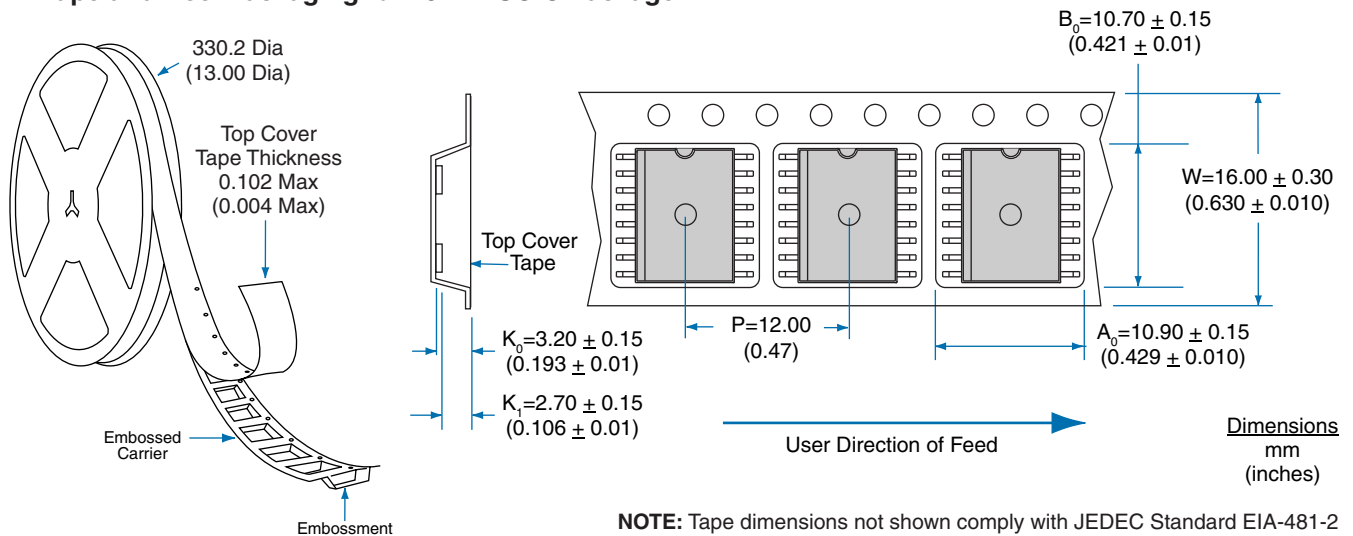

NOTE: Tape dimensions not shown comply with JEDEC Standard EIA-481-2

3.3.2 MLP

Tape and Reel Packaging for 6mm x 7mm 16-Pin MLP Package

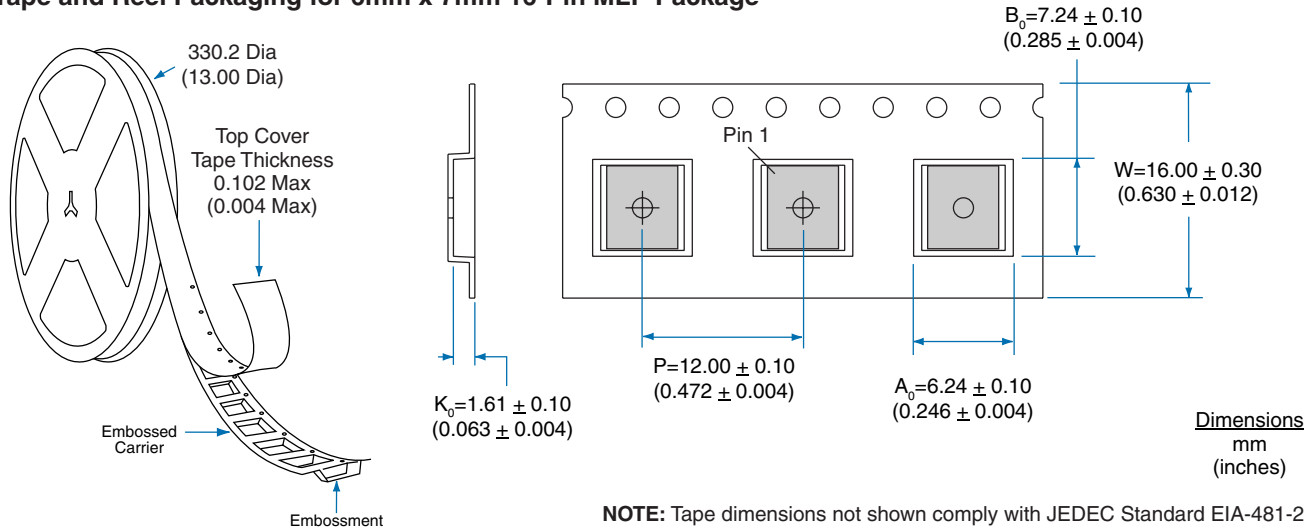

3.4 Soldering

3.4.1 Moisture Reflow Sensitivity

Clare has characterized the moisture reflow sensitivity for this product using IPC/JEDEC standard J-STD-020. Moisture uptake from atmospheric humidity occurs by diffusion. During the solder reflow process, in which the component is attached to the PCB, the whole body of the component is exposed to high process temperatures. The combination of moisture uptake and high reflow soldering temperatures may lead to moisture induced delamination and cracking of the component. To prevent this, this component must be handled in accordance with IPC/JEDEC standard J-STD-033 per the labeled moisture sensitivity level (MSL), level 1 for the SOIC package, and level 3 for the MLP package.

3.4.2 Reflow Profile

For proper assembly, this component must be processed in accordance with the current revision of IPC/JEDEC standard J-STD-020. Failure to follow the recommended guidelines may cause permanent damage to the device resulting in impaired performance and/or a reduced lifetime expectancy.

3.5 Washing

Clare does not recommend ultrasonic cleaning of this part.



For additional information please visit www.clare.com

Clare, Inc. makes no representations or warranties with respect to the accuracy or completeness of the contents of this publication and reserves the right to make changes to specifications and product descriptions at any time without notice. Neither circuit patent licenses or indemnity are expressed or implied. Except as set forth in Clare's Standard Terms and Conditions of Sale, Clare, Inc. assumes no liability whatsoever, and disclaims any express or implied warranty relating to its products, including, but not limited to, the implied warranty of merchantability, fitness for a particular purpose, or infringement of any intellectual property right.

The products described in this document are not designed, intended, authorized, or warranted for use as components in systems intended for surgical implant into the body, or in other applications intended to support or sustain life, or where malfunction of Clare's product may result in direct physical harm, injury, or death to a person or severe property or environmental damage. Clare, Inc. reserves the right to discontinue or make changes to its products at any time without notice.

Specifications: DS-CPC1466 - R00B
© Copyright 2007, Clare, Inc.
All rights reserved. Printed in USA.
6/29/2007