

Parameter	Rating	Units
Blocking Voltage	70	V <sub>p</sub>
Load Current	150	mA
Max On-Resistance	16	Ω
LED Current to Operate	1	mA

### Transient Protection Characteristics

Part Number	Peak Pulse Power	V <sub>WM</sub>
CPC1317	600W	40.2V

### Features

- Small 8-Pin Surface-Mount Package
- Low Drive Power Requirements (TTL/CMOS Compatible)
- No Moving Parts
- High Reliability
- Arc-Free With No Snubbing Circuits
- 3750V<sub>rms</sub> Input/Output Isolation
- No EMI/RFI Generation
- Machine Insertable, Wave Solderable

### Applications

- Sensor Circuitry
- Instrumentation
- Multiplexers
- Data Acquisition
- Electronic Switching
- I/O Subsystems
- Security
- Aerospace
- Industrial Controls

### Description

The CPC1317 is a 1-Form-A solid state relay with bi-directional transient voltage suppressor (TVS) relay protection, which is designed to meet the requirements of EN50130-4 (installation class 3). Clare's patented OptoMOS architecture, with efficient MOSFET switches and photovoltaic die, provides 3750V<sub>rms</sub> of input-to-output isolation. Highly efficient GaAlAs infrared LEDs control the optically coupled input.

The CPC1317 is available in an 8-pin, space-saving surface-mount package.

### Approvals

- UL Recognized Component File: E76270
- EN/IEC 60950-1 compliant

### Ordering Information

Part #	Description
CPC1317P	8-Pin Flatpack (50/tube)
CPC1317PTR	8-Pin Flatpack (1000/reel)

### Pin Configuration

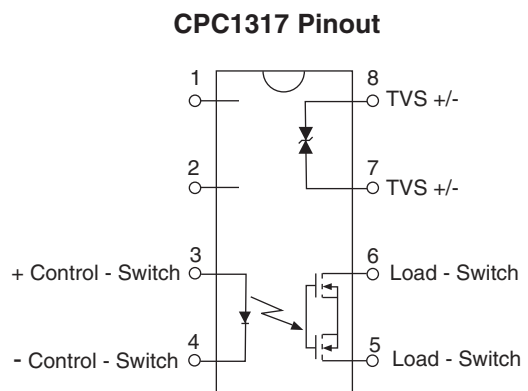

### Switching Characteristics of Normally Open (Form A) Devices

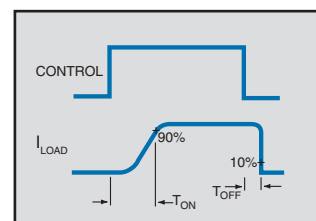

## Absolute Maximum Ratings

Parameter	Ratings	Units
SSR Output Blocking Voltage	70	V <sub>P</sub>
TVS Working Voltage, Maximum	40.2	V
Reverse Input Voltage	5	V
Input Control Current Peak (10ms)	50	mA
	1	A
Input Power Dissipation <sup>1</sup>	150	mW
SSR Output Power Dissipation <sup>2</sup>	400	mW
TVS Peak Pulse Power (I <sub>pp</sub> =9.3A, 10/1000μs pulse)	600	W
Isolation Voltage Input to Output	3750	V <sub>rms</sub>
Operating Temperature	-40 to +85	°C
Storage Temperature	-40 to +125	°C

<sup>1</sup> Derate Linearly 1.33 mw / °C

<sup>2</sup> Derate Linearly 6.67 mw / °C

Electrical absolute maximum ratings are at 25°C

Absolute Maximum Ratings are stress ratings. Stresses in excess of these ratings can cause permanent damage to the device. Functional operation of the device at conditions beyond those indicated in the operational sections of this data sheet is not implied.

## SSR Electrical Characteristics

Parameter	Conditions	Symbol	Min	Typ	Max	Units
<b>Output Characteristics @ 25°C</b>						
Load Current Continuous	-	I <sub>L</sub>	-	-	150	mA
	t=10ms	I <sub>LPK</sub>	-	-	400	
Peak						
On-Resistance <sup>1</sup>	I <sub>L</sub> =150mA, I <sub>F</sub> =1mA	R <sub>ON</sub>	-	7	16	Ω
Off-State Leakage Current	V <sub>L</sub> =70V	I <sub>LEAK</sub>	-	-	1	μA
<b>Switching Speeds</b>						
Turn-On	I <sub>F</sub> =5mA, V <sub>L</sub> =10V	T <sub>ON</sub>	-	-	2.5	ms
		T <sub>OFF</sub>	-	-	2.5	
Turn-Off						
Output Capacitance	50V; f=1MHz	C <sub>OUT</sub>	-	25	-	pF
<b>Input Characteristics @ 25°C</b>						
Input Control Current <sup>2</sup>	I <sub>L</sub> =150mA	I <sub>F</sub>	-	-	1	mA
Input Dropout Current	-	I <sub>F</sub>	0.1	-	-	mA
Input Voltage Drop	I <sub>F</sub> =5mA	V <sub>F</sub>	0.9	1.2	1.4	V
<b>Common Characteristics @ 25°C</b>						
Capacitance Input to Output	-	C <sub>I/O</sub>	-	3	-	pF

<sup>1</sup> Measurement taken within 1 second of turn-on time.

<sup>2</sup> For applications requiring high temperature operation (> 60°C) a minimum LED drive current of 3mA is required.

## TVS Electrical Characteristics

Parameter	Conditions	Symbol	Min	Typ	Max	Units
Clamping Voltage	I <sub>pp</sub> =9.3A	V <sub>C</sub>	-	-	66.5	V
Reverse Breakdown Voltage	I <sub>BR</sub> =1mA	V <sub>BR</sub>	44.4	-	-	V
Reverse Leakage Current	V <sub>WM</sub> =40.2V	I <sub>D</sub>	-	-	5	μA

**PERFORMANCE DATA\***

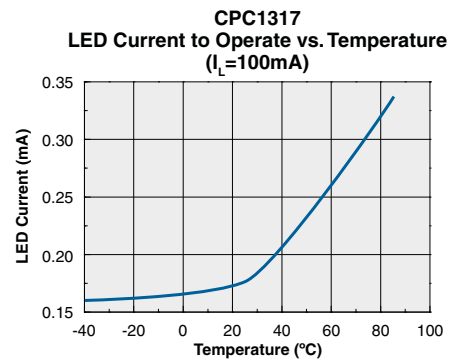
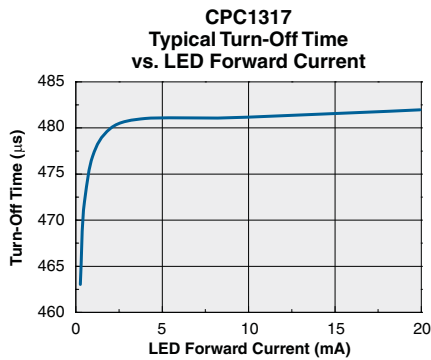
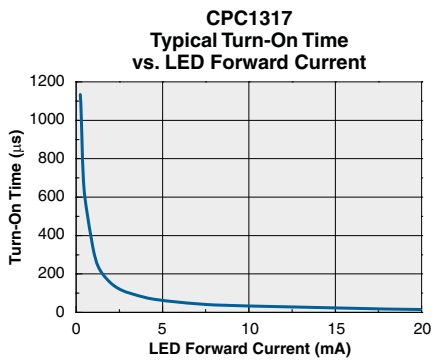
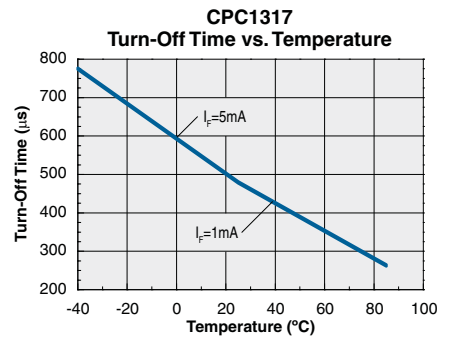
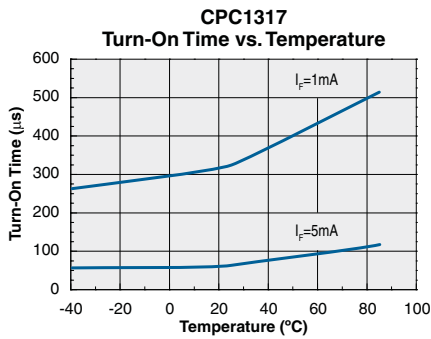
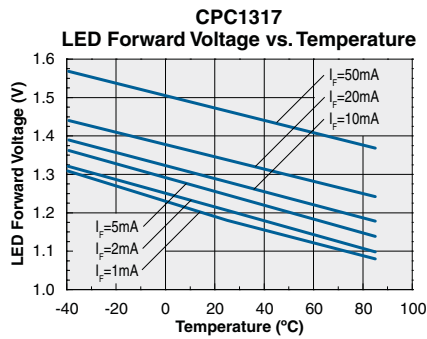
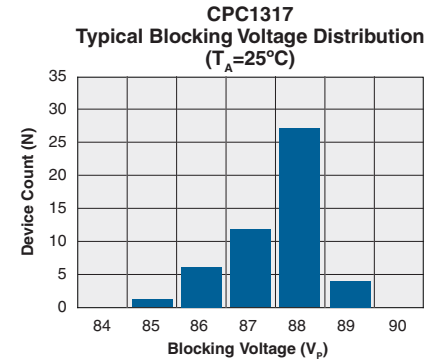
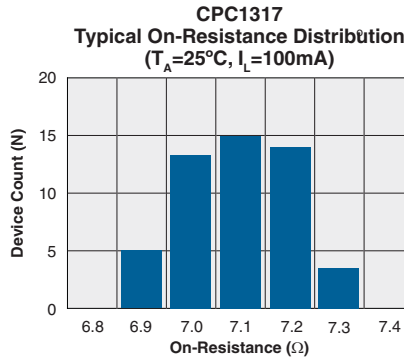
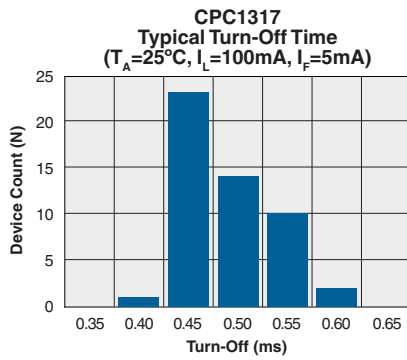
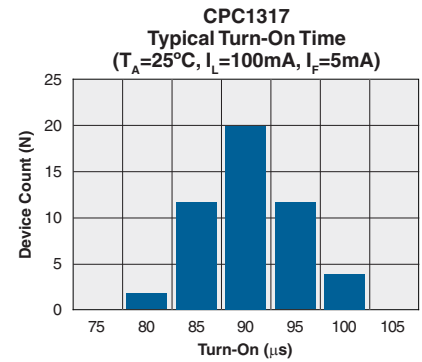
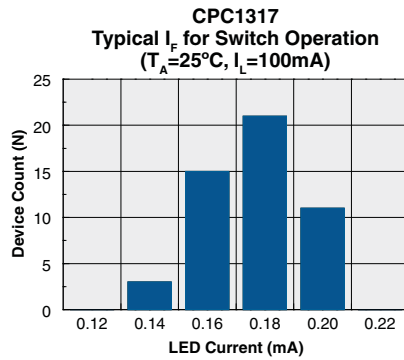
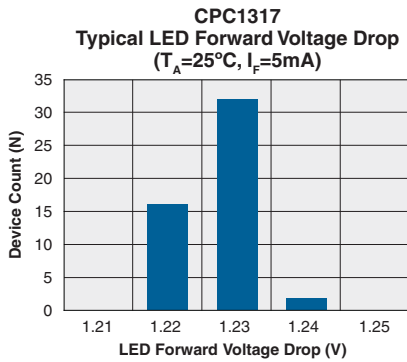

\*The Performance data shown in the graphs above is typical of device performance. For guaranteed parameters not indicated in the written specifications, please contact our application department.

PERFORMANCE DATA\*

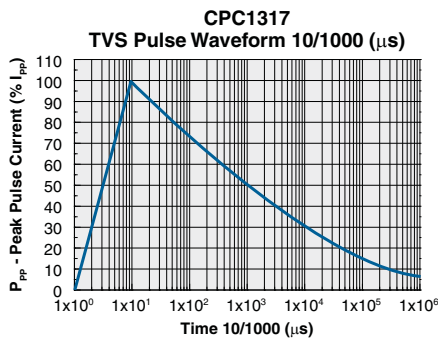
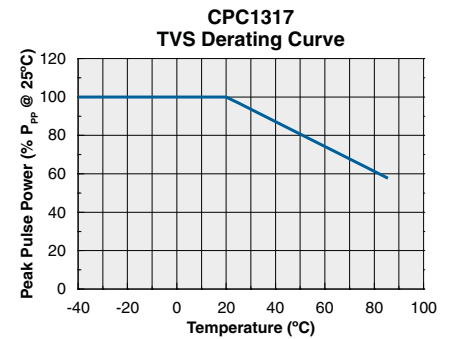
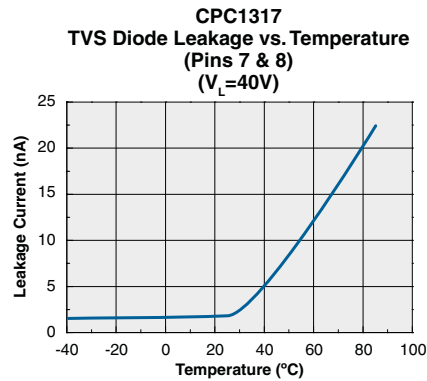
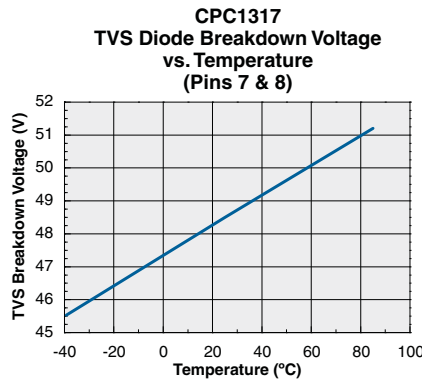
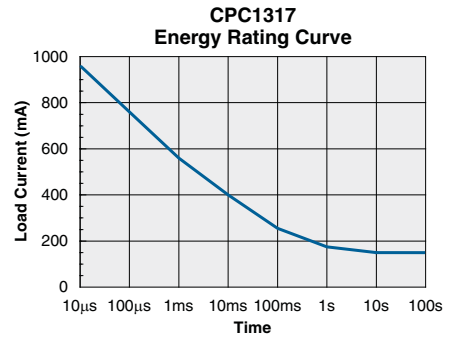
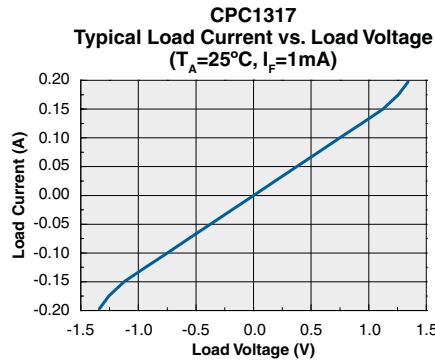
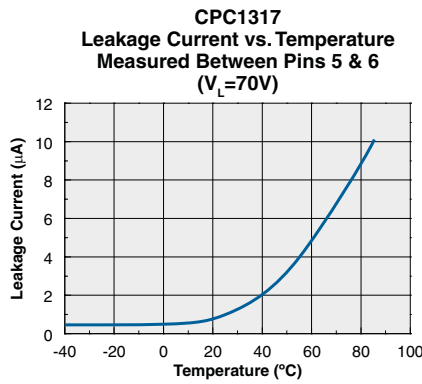
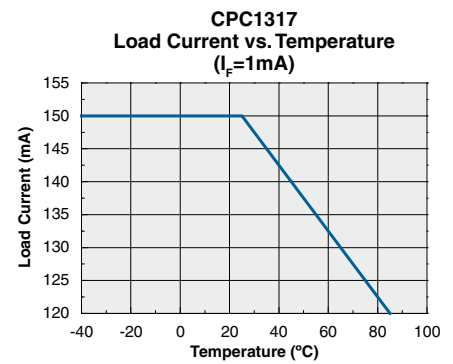
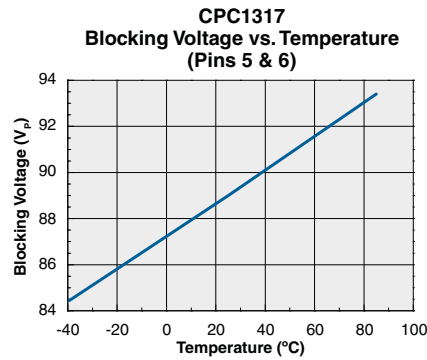
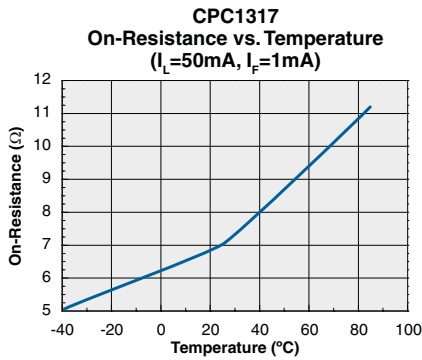

\*The Performance data shown in the graphs above is typical of device performance. For guaranteed parameters not indicated in the written specifications, please contact our application department.

## MANUFACTURING INFORMATION

### Soldering

For proper assembly, the component must be processed in accordance with the current revision of IPC/JEDEC standard J-STD-020. Failure to follow the recommended guidelines may cause permanent damage to the device resulting in impaired performance and/or a reduced lifetime expectancy.

### Washing

Clare does not recommend ultrasonic cleaning or the use of chlorinated solvents.



## MECHANICAL DIMENSIONS

### 8 Pin Flatpack Package

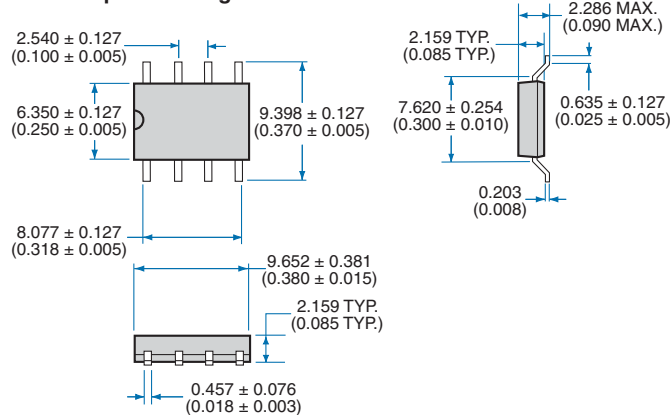

### Recommended PCB Land Pattern

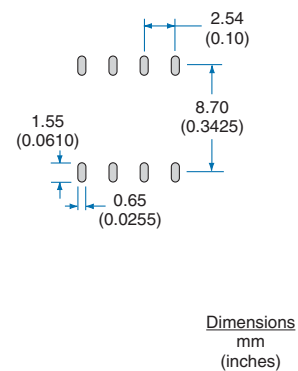

### Tape and Reel Packaging for 8 Pin Flatpack Package

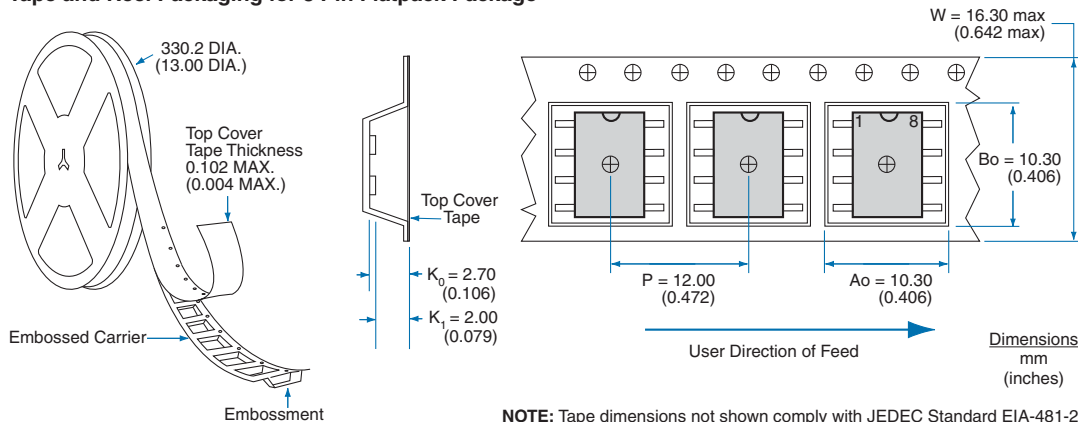

NOTE: Tape dimensions not shown comply with JEDEC Standard EIA-481-2

## For additional information please visit our website at: [www.clare.com](http://www.clare.com)

Clare, Inc. makes no representations or warranties with respect to the accuracy or completeness of the contents of this publication and reserves the right to make changes to specifications and product descriptions at any time without notice. Neither circuit patent licenses nor indemnity are expressed or implied. Except as set forth in Clare's Standard Terms and Conditions of Sale, Clare, Inc. assumes no liability whatsoever, and disclaims any express or implied warranty, relating to its products including, but not limited to, the implied warranty of merchantability, fitness for a particular purpose, or infringement of any intellectual property right.

The products described in this document are not designed, intended, authorized or warranted for use as components in systems intended for surgical implant into the body, or in other applications intended to support or sustain life, or where malfunction of Clare's product may result in direct physical harm, injury, or death to a person or severe property or environmental damage. Clare, Inc. reserves the right to discontinue or make changes to its products at any time without notice.