

## 1 Using the CPC1590 Isolated Gate Driver IC

The CPC1590 is an excellent choice for remote switching of DC and low frequency loads where isolated power is unavailable. The device uses external components to satisfy design switching requirements, which enables the designer to choose from a great number of MOSFETs. The designer also has several options when designing over-voltage protection circuitry. The case studies look at only two of many methods, but each has unique constraints that should prove useful to many other designs.

**Figure 1** shows a typical application circuit for using the CPC1590 gate driver. The part allows the user to turn on the gate of a MOSFET and keep it on until the LED current is turned off. The application circuit uses a

boot-strap diode (internal to the part) and storage capacitor ( $C_{ST}$ ) to provide the charge needed for fast turn-on switching of an external MOSFET device. When the MOSFET is on, the photo current from the LED keeps the MOSFET gate biased to the rated voltage continuously.

The CPC1590 uses charge from the load voltage when turning off to restore the MOSFET gate's switching charge for the next turn-on event. The part will turn on even without the recovery (in the case of no load voltage), although the turn-on will be much slower because the photo current will be charging the gate. This feature can be exploited during system startup.

## 2 Application Component Selection

### 2.1 Storage Capacitor Selection $C_{ST}$

The storage capacitor ( $C_{ST}$ ) enables the part to turn on quickly by holding a reservoir of charge to be transferred to the gate of the MOSFET. The turn-off cycle does not depend on the storage capacitor.

**Equation 1:** Charge Storage Capacitor Calculation:

$$C_{ST} \geq \frac{Q_G}{0.5V} \quad (\text{FARADS})$$

$Q_G$  is the total gate charge. Equation 1 shows that the storage capacitor needs to deliver enough charge to the gate while only dropping 0.5V. The CPC1590 can deliver 32nC at the rated operating speed and will

operate with much larger loads (<4uF) with a slower turn-on and turn-off time.

**Note:** Care must be taken to minimize any leakage current path from the capacitor to ground, between pins 7 and 8, MOSFET gate current, and between pins 5 and 6. Leakage currents will discharge the storage capacitor and, even though the device is already on, will become a load to the photo current that keeps the gate voltage on. The gate voltage will be reduced if >500nA of leakage is present. Therefore, the combined impedance from pin 8 to pin 7, pin 5 and pin 6, capacitor current, and MOSFET current must be >20M $\Omega$  over the temperature rating of the part.

**Figure 1 CPC1590 Application Circuit Diagram with Over-Voltage Protection**

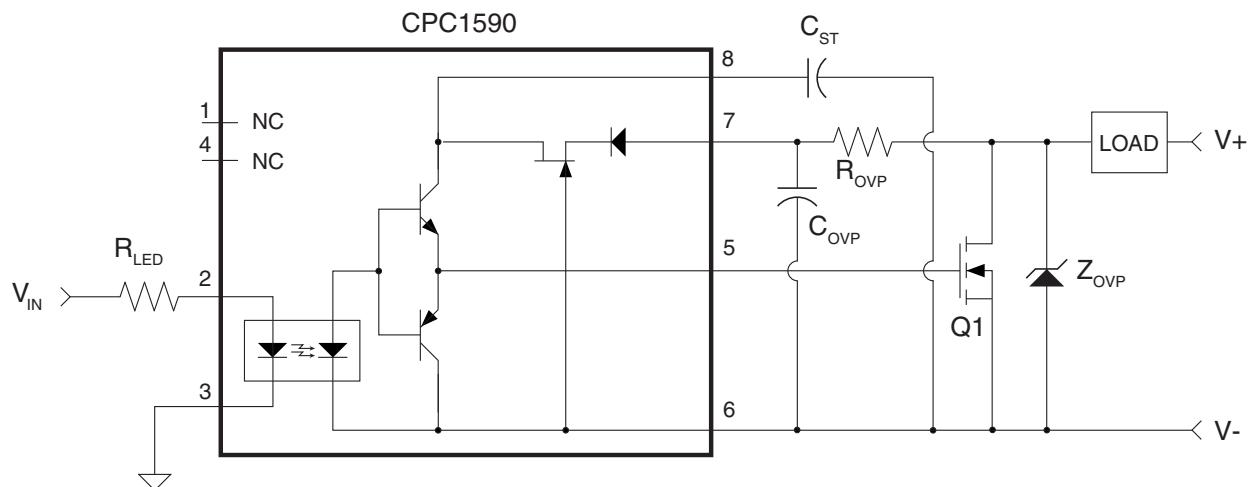

## 2.2 Transistor Selection

The CPC1590 charges and discharges an external MOSFET transistor. The selection of the MOSFET is determined by the user to meet the specific power requirements for the load. The CPC1590 output voltage is listed in the specification, but, as mentioned earlier, there must be little or no gate leakage.

Another parameter that plays a significant role in the determination of the transistor is the gate drive voltage available from the part. The CPC1590 uses photovoltaic cells to collect the optical energy generated by the LED, and to generate more voltage the photovoltaic diodes are stacked. As such, the voltage of the photovoltaic stack reduces with increased temperature. The user must select a transistor that will maintain the load current at the maximum temperature, given the  $V_{GS}$  in the CPC1590 specification.

The case studies below use "logic-level" MOSFETs for each design to maintain the load described.

### 2.2.1 Transistor Switching Characteristics

The primary characteristics of the application's switching behavior are  $t_{ON}$ ,  $t_{OFF}$ ,  $t_{RISE}$ ,  $t_{FALL}$ , and the recovery time of the storage capacitor,  $t_{CHG}$ . These parameters are dependent on the MOSFET selection and need to be reviewed in light of the application requirements.

The CPC1590 turns on the MOSFET to the datasheet  $V_{GS}$  after the  $t_{ON}$  delay. Similarly the  $t_{OFF}$  delay is the amount of time until the LED is turned off and the capacitive load discharges to the level in the CPC1590 specification. For MOSFETs with larger or smaller required gate charge the  $t_{ON}$  and  $t_{OFF}$  will be proportionately faster or slower, but it is not a linear relationship.

The approximate rise and fall times of the transistor's drain voltage is:

**Equation 2:** Rise Time Calculation:

$$t_{RISE,VD} \approx \frac{V_{LOAD} \cdot C_{RSS}}{I_{G\_SINK}} \quad (\text{SECONDS})$$

**Equation 3:** Fall Time Calculation:

$$t_{FALL,VD} \approx \frac{V_{LOAD} \cdot C_{RSS}}{I_{G\_SOURCE}} \quad (\text{SECONDS})$$

Where  $C_{RSS}$  is the MOSFET gate-drain capacitance (averaged over the switching voltage range) found in the MOSFET datasheet, and  $I_{G\_SINK}$  is the gate sinking current of the CPC1590, and  $I_{G\_SOURCE}$  is the gate driving ability.

For a significant number of applications, the rise time will likely be dominated by the CPC1590's internal discharge time. This can alter the amount of dissipated energy in the MOSFET during switching so the user must review the application carefully as shown in the design examples.

The value for the charge time,  $t_{CHG}$  is due to external component selection.

To calculate the value for the charge time,  $t_{CHG}$ , which is due to external component selection:

**Equation 4:** Storage Capacitor Charge Recovery Time (seconds):

$$t_{CHG} \approx 5 \cdot 300\Omega \cdot C_{ST}$$

***Note:** The CPC1590 is ideal to use where remote power is otherwise unavailable. If the LED is also powered remotely, care must be taken to ensure that parasitic transient signals are reliably filtered from the input control signal. Large transient currents will mutually couple energy between cables and a simple R-C filtering of the CPC1590 input may be sufficient to suppress false turn-on.*

### 3 Application Switching Losses

During the transition intervals, the application and load components change energy states and during the process incur switching losses. The switching losses are manifested as heat in the application circuit, and must be addressed by the designer to ensure that no one component exceeds its power rating. The designer must understand the details of load behavior in order to adequately size and protect the application circuit. There are three general cases to observe: (1) purely resistive loads, (2) inductive/resistive loads, and (3) loads with significant capacitance. Inductors and capacitors are energy storage elements that require special consideration for switching.

During the switching periods, of course, energy is conserved. Inductors turning off transfer their stored energy to MOSFET switching losses, capacitance of the load and application circuit, and to the protector.

During the turn-on interval, the inductor energy is zero, and so the capacitive energy in the load and parasitic elements of the switching application must be dissipated by the MOSFET in order for the load to change state.

**Equation 5:** Stored Inductive Energy (Joules):

$$E_L = \frac{1}{2} \cdot L \cdot I_{LOAD}^2$$

#### 3.1 Resistive Load Losses: The Ideal Case

For purely resistive loads, the energy dissipated by changing states occurs primarily in the MOSFET. The equation describing MOSFET energy dissipation is:

**Equation 6:** MOSFET Energy:  $E_{RISE}$  (Joules):

$$E_{MOSFET} \geq V_{LOAD}^2 \cdot \frac{C_{RSS}}{I_{G\_SINK}} \cdot \frac{I_{LOAD}}{6} = \frac{P_{LOAD}}{6} \cdot t_{RISE}$$

The average power of the MOSFET for any load type is:

**Equation 7:** MOSFET Average Power (Watts):

$$P_{AVG} = I_{LOAD}^2 \cdot R_{DSAT} \cdot D + f_{SWITCH} \cdot (E_{RISE} + E_{FALL})$$

Where  $f_{SWITCH}$  is the application switching frequency,  $R_{DSAT}$  is the MOSFET's on-resistance, and  $D$  is the switch's operational duty cycle:  $D = t_{ON}/(t_{ON}+t_{OFF})$ .

$E_{RISE}$  and  $E_{FALL}$  represent the energy dissipated by the MOSFET during rise and fall, in Joules.

#### 3.2 Inductive/Resistive Loads

If the load is resistive and inductive, and the inductance doesn't saturate, then the load current during turn off is described by:

**Equation 8:** Resistive/Inductive Load Current during  $t_{RISE}$  (Amps):

$$I_{LOAD}(t) = \frac{V_{LOAD}}{R_{LOAD}} - \frac{I_{G\_SINK}}{L_{LOAD} \cdot C_{RSS}} \cdot \left( \frac{L_{LOAD}}{R_{LOAD}} \right)^2 \cdot \left[ \frac{R_{LOAD}}{L_{LOAD}} \cdot t - 1 + e^{-\frac{R_{LOAD}}{L_{LOAD}} \cdot t} \right]$$

The drain voltage during turn off is:

**Equation 9:** MOSFET Drain Voltage during  $t_{RISE}$  (V):

$$V_{DRAIN}(t) = \frac{I_{G\_SINK}}{C_{RSS}} \cdot t$$

The instantaneous power in the MOSFET will be the product of the two equations, and the energy will be the integral of the power over time.

#### 3.3 Capacitive Loads

The energy absorbed by the MOSFET for loads that are more capacitive in nature occurs during the MOSFET turn-on as opposed to the turn-off. The energy absorbed by the MOSFET will be a function of the load, the TVS (or other protector) and the MOSFET drain capacitance.

**Equation 10:** MOSFET Energy:  $E_{FALL}$  (Joules):

$$E_{FALL} = \frac{1}{2} \cdot (C_{TVS} + C_{OSS} + C_{LOAD}) \cdot V_{LOAD}^2$$

$C_{OSS}$  is the MOSFET output capacitance found in the datasheet. As mentioned earlier, the MOSFET switching losses occur at different times, either rising or falling, so loads with a combination of inductance and capacitance can also be calculated by the energy equations described above.

## AN-202

The MOSFET can dissipate repeated avalanche energy, found in the datasheet, however that energy must be reduced for increased ambient temperature. For a 150°C MOSFET, the energy reduction at  $T_{J,MAX}$  is:

**Equation 11:** MOSFET Energy Adjustment for Operating conditions (Joules):

$$E(T_{J,MAX}) \leq E(25^{\circ}\text{C}) \cdot \frac{(150^{\circ}\text{C} - T_{J,MAX})}{(150^{\circ}\text{C} - 25^{\circ}\text{C})}$$

$T_{J,MAX}$  is the junction temperature of the die, so it must include the temperature increase caused by power dissipation of the load and the thermal impedance of the package/application.  $E(25^{\circ}\text{C})$  is the repetitive avalanche energy,  $E_{AR}$ , in the MOSFET datasheet at 25°C.

### 3.4 dV/dt Characteristics

The application shown in [Figure 1](#) and the detailed design of Case 1, [See “Case 1: 180V Application”](#)

## 4 Design Switching Frequency

The maximum switching frequency is the last design value to be calculated, because the over-voltage protection and storage capacitor play a significant role in determining the result. Because those factors are already determined, the following gives a good approximation for the maximum switching frequency. The maximum switching frequency is a function of the Gate charge of the MOSFET, the storage capacitor ( $C_{ST}$ ), and  $R_{OVP}$ . The maximum switching frequency relationship is:

**Equation 12:** Maximum Switch Operation (Hz):

$$f_{MAX} \leq \frac{1}{M} \cdot (t_{ON} + t_{OFF} + (t_{RISE,VD} \mid t_{CHG}) + t_{FALL,VD})^{-1}$$

where  $M=3$  and is a multiplication factor for temperature and process variations;  $t_{ON}$  and  $t_{OFF}$  are CPC1590 datasheet parameters;  $t_{RISE,VD}$  is the rise time of the drain voltage and  $t_{CHG}$  is the charge time of the storage capacitor,  $C_{ST}$ , and overvoltage protection circuitry;  $t_{FALL,VD}$  is the fall time across the transistor. For calculation, choose the greater of  $t_{RISE,VD}$  or  $t_{CHG}$ .

There is no minimum switching frequency because the CPC1590 uses photovoltaic diode current to keep the output charged as long as LED current flows.

**Circuit” on page 6**, dissipates significant energy caused by large dV/dt events. Fault voltages across the MOSFET will turn it on for the same reason that the part turns off slowly. For dV/dt events  $> I_{G\_SINK}/C_{RSS}$  (from Equation 2) the application circuit will dissipate energy proportional to the  $C_{RSS}$  and  $g_{FS}$  (forward conductance) of the selected transistor.  $C_{RSS}$  is a function of the transistor's on-resistance and current/power capability, so higher load-power designs are more sensitive.

The CPC1590 provides an internal clamp to protect the gate of the MOSFET from damage during such an event. The part can withstand 100mA for short periods, such as dV/dt transients.

**Note:** *The CPC1590 is ideal to use where remote power is otherwise unavailable. If the LED is also powered remotely, care must be taken to ensure that parasitic transient signals are reliably filtered from the input control signal. Large transient currents will mutually couple energy between cables and a simple R-C filtering of the CPC1590 input may be sufficient to suppress false turn-on.*

## 5 CPC1590 Over-Voltage Protection

Over-voltage protection is generally required for the CPC1590 because of parasitic inductance in the load, wires, board traces, and axial leads of protectors. Purely resistive loads, or loads with low voltage switching, may be able to rely on the transistor to handle any parasitic energy, and thereby not require protection for the CPC1590. For very low inductance loads and traces, over-voltage suppression may be handled with a simple R-C filter consisting of  $R_{OVP}$  and  $C_{OVP}$ , or by use of a free-wheeling diode. For more moderate load inductance, or for remote switching of a load (i.e. through a long cable) a voltage suppressor can be used. For heavily inductive loads, only a free-wheeling diode,  $D_{OVP}$ , connected across the load element is recommended, see **Figure 2**.

The energy not consumed in switching losses must be absorbed by the over-voltage protection element. Most protective devices are designed to withstand certain peak power, in the case of a TVS, or maximum avalanche energy, in the case of a MOSFET. Understanding the switching losses and load dynamics is absolutely essential.

One simple way to reduce the amount of stored inductive energy is to increase the energy dissipated in the switch. This can be accomplished by adding a larger capacitor in parallel with the gate-drain connection of the MOSFET, however care must be taken such that the rise-time and peak current does not exceed the Safe Operating Area (SOA) rating of the transistor. The consequence of increasing the gate-drain effective capacitance is reduced  $dV/dt$  tolerance.

**Figure 2 CPC1590 Over-Voltage Protection for Inductive Loads**

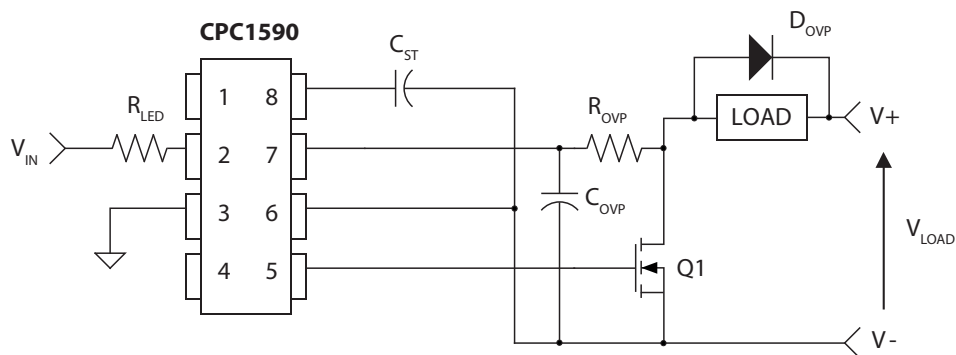

### 5.1 Other Protection Techniques

For applications in which higher inductance loads are switched, the designer must consider other circuit techniques, device ratings, or protector types. Of paramount importance is that the designer know the characteristics of the load being switched.

An excellent source describing power electronic devices and switching behavior is: Power Semiconductor Devices, by B. Jayant Baliga, ISBN 0-543-94098-6.

For more over-voltage protection circuit techniques consult: Switchmode Power Supply Handbook, 2nd Edition, Keith Billings, ISBN 0-07-006719-8, or Power MOSFET Design, B. E. Taylor, ISBN 0-471-93802-5.

## 6 Design Examples

**Table 1:** Shows two sample application component selections for two different voltage ratings.

### 6.1 Case 1: 180V Application Circuit

The application circuit selected uses a 200V MOSFET in conjunction with the CPC1590. The operating voltage allows 20V  $B_{VDSS}$  breakdown reduction for low temperature operation (-40C). This sample application does not include an over-voltage protector, so the parasitic inductance and load current will need to be less than the repetitive avalanche energy of the

MOSFET, derated for high temperature (see Equation 11) to  $0.183 \cdot E(25^{\circ}\text{C})$  or 1.26mJ.

The 180V application has the following calculated values from the equations above:  $t_{RISE}=4.75\mu\text{s}$  and  $t_{FALL}=1.73\mu\text{s}$ , the calculated voltage drop of the storage capacitor ( $C_{ST}$ ) = 0.26V, from  $Q_G=26\text{nC}$ . The calculated MOSFET energy dissipated during  $t_{RISE}$  is 135 $\mu\text{J}$  and the energy during  $t_{FALL}$  is negligible.

**Table 1: Sample Application Components**

Device	180V/1A Value/Rating	48V/5A Value/Rating	Comment
Q1	IRLWI630A <sup>3</sup>	FQP20N06L <sup>3</sup>	MOSFETS
$C_{ST}$	>0.1 $\mu\text{F}/100\text{V}$	>0.01 $\mu\text{F}/100\text{V}$	5% Capacitor
$Z_{OVP}$	Not Used	SA48A <sup>3</sup>	TVS-style protector
$R_{OVP}$	1K $\Omega$	5.1K $\Omega$	5%, 1/8 Watt (60Hz Switching Frequency or less)
$C_{OVP}$	0.001 $\mu\text{F}$ , 400V	0.001 $\mu\text{F}$ , 100V	5% Capacitor
$R_{LED}$	680 $\Omega$	680 $\Omega$	5V Switching

<sup>1</sup> An excellent source describing power electronic devices and switching behavior is: *Power Semiconductor Devices*, by B. Jayant Baliga, ISBN 0-543-94098-6

<sup>2</sup> For more over-voltage protection circuit techniques consult: *Switchmode Power Supply Handbook, 2<sup>nd</sup> Edition*, Keith Billings, ISBN 0-07-006719-8, or *Power MOSFET Design*, B. E. Taylor, ISBN 0-471-93802-5.

<sup>3</sup> To completely understand the examples given, use of the product datasheets for the components specified in the table.

**Figure 3 Voltage Drop on  $C_{ST}$**

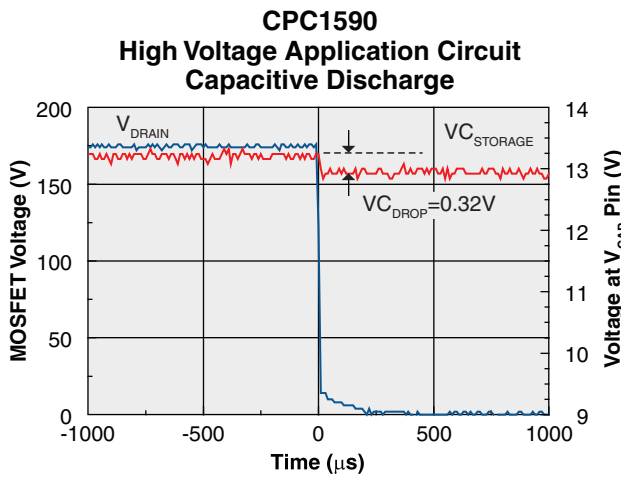

**Figure 4 CPC1590 Application During Turn-Off**

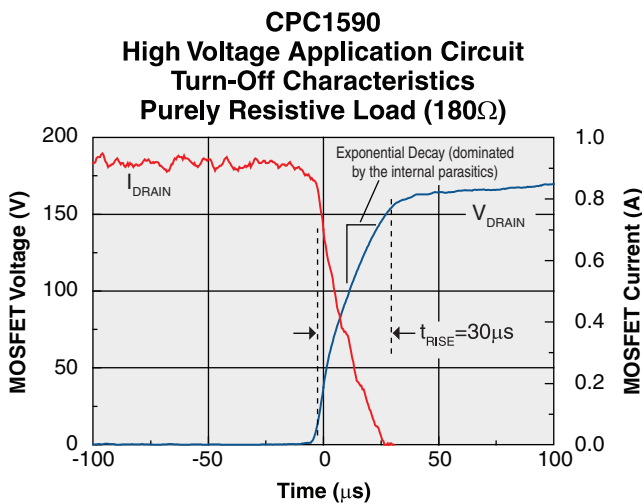

**Figure 5 CPC1590 Application During Turn-On**

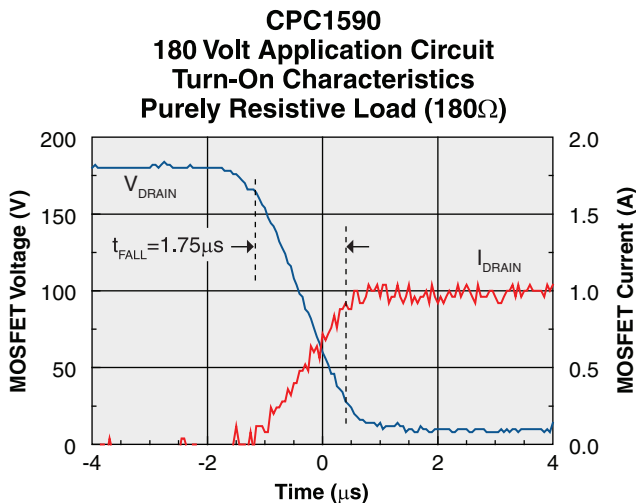

**Figure 6 MOSFET Power and Energy**

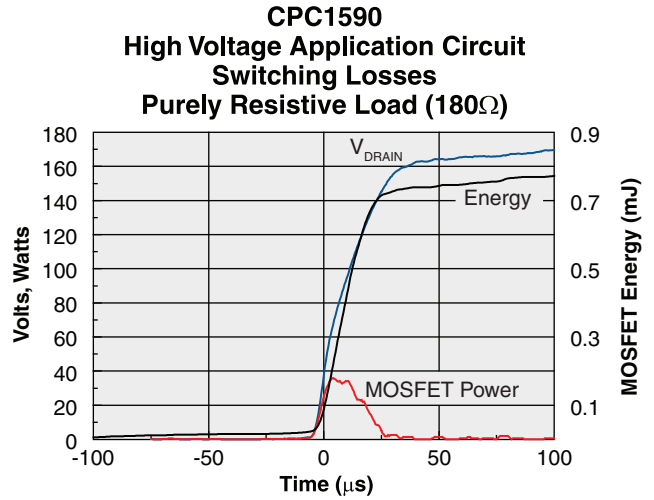

**Figure 7 CPC1590 Gate Drive Parasitic Behavior**

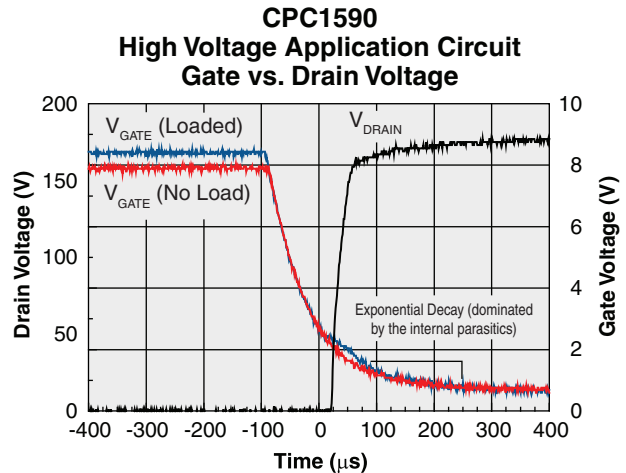

6.2 Case 1: (Continued)

The load was modified by adding 630μH of inductance in series with the load resistor. The purpose is to emulate a leakage inductance or mutual inductance that may represent a load characteristic. **Figure 8** shows the turn-on behavior, and **Figure 9** shows the turn-off behavior with the load.

While **Figure 9** shows a small amount of peaking as the switch turns off, it is clear that avalanche breakdown is avoided. This is further demonstrated by the energy dissipated in the MOSFET exceeding the energy stored in the magnetic inductance.

**Figure 10** shows how much power is dissipated in the MOSFET during turn-off, and the energy absorbed during the turn-off event. From the graph the user can see 750μJ is absorbed in the MOSFET while only 315μJ was stored in the inductor.

A final design will characterize  $t_{RISE}$  of the entire application at the maximum operating temperature and derate the avalanche energy ( $E_{AR}$  in the datasheet,) accordingly.

Figure 8 630μH Turn-On

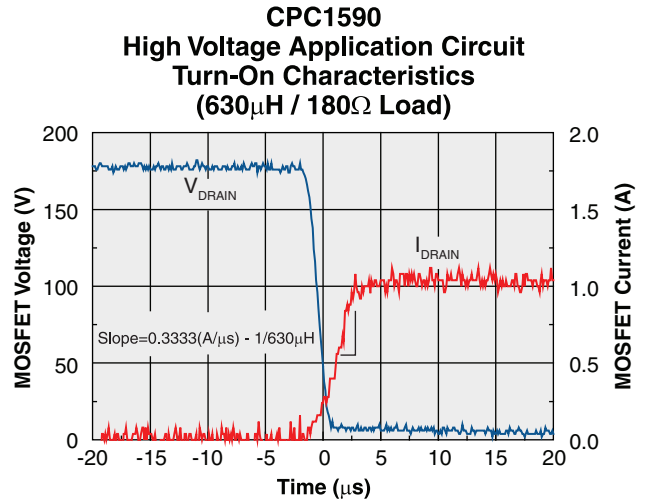

Figure 9 630μH Turn-Off

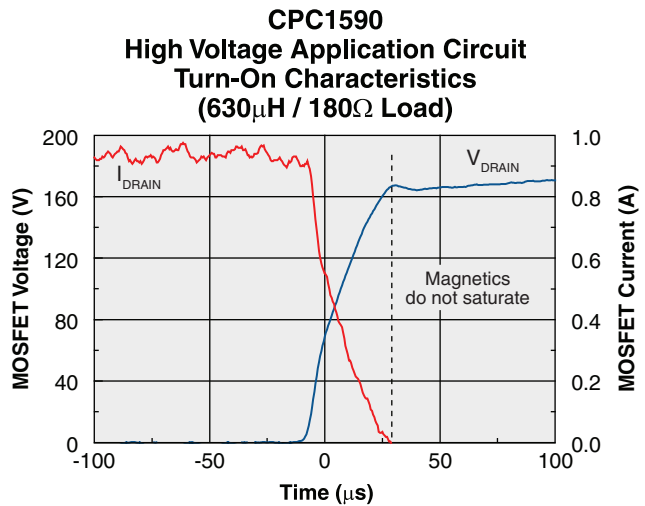
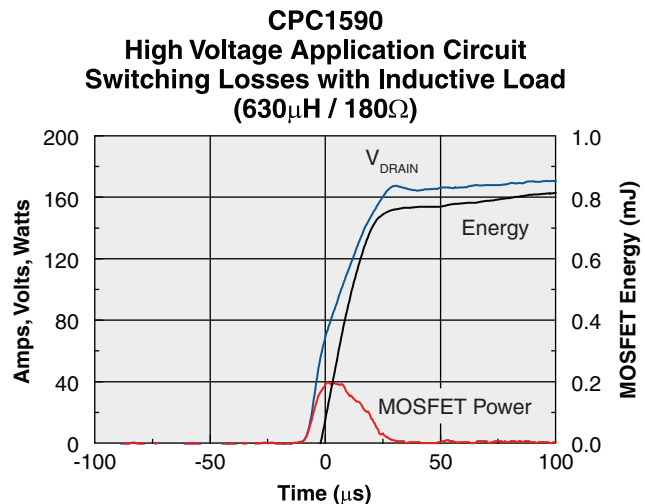

Figure 10 630μH MOSFET Power and Energy



### 6.3 Case 2: 48V Application Circuit

The CPC1590 can be used over a wide range of load voltages, some as low as 15V. An identical application circuit was used with the CPC1580, so for comparison the application circuit was adjusted for the CPC1590. The results are essentially identical for all factors between the CPC1590 and CPC1580 at 48V.

Rise and fall times shown in **Figure 11** and **Figure 12** which are limited by decay times internal to the part (shown in **Figure 13**). The peak power and energy shown in **Figure 14** are well below the peak power and power restrictions shown in the MOSFET datasheet.

Figure 13 CPC1590 48V Gate Discharge

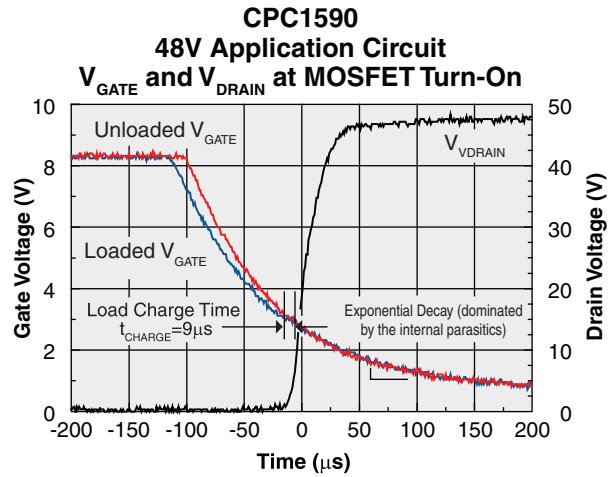

Figure 11 CPC1590 48V  $t_{FALL}$

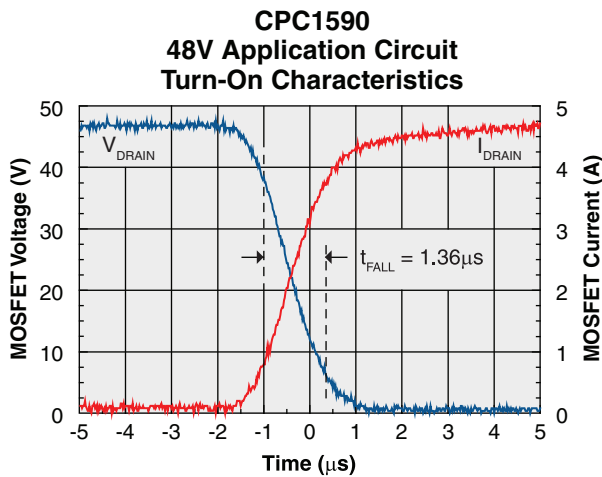

Figure 14 48V MOSFET Power and Energy

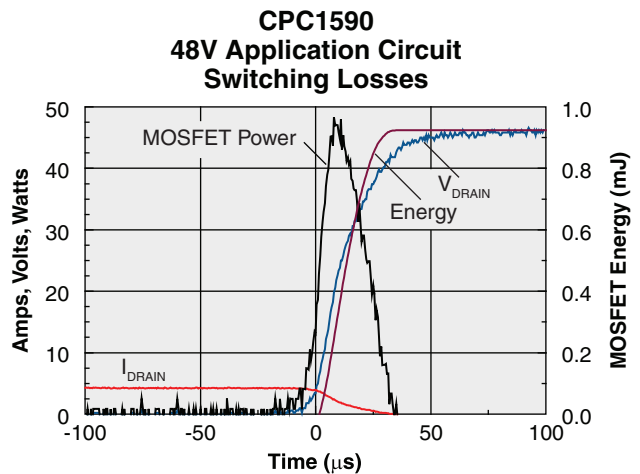
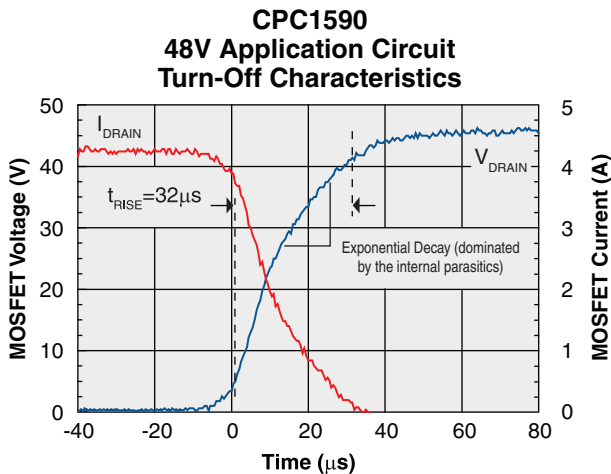

Figure 12 CPC1590 48V  $t_{RISE}$



## 6.4 Other Application Circuits

### 6.4.1 AC Relay Application Circuit

The CPC1590 can be used in other configurations. One typical configuration, an “AC Switch,” is shown in **Figure 15**. “AC Switch” simply means that either terminal can be positive or negative. This configuration requires a second MOSFET (Q2) and two rectifying diodes (D1 and D2).

The design considerations are identical for this application. Diodes D1 and D2 must have a voltage rating greater than the peak load voltage.

**Figure 15 CPC1590 AC Relay Application Circuit**

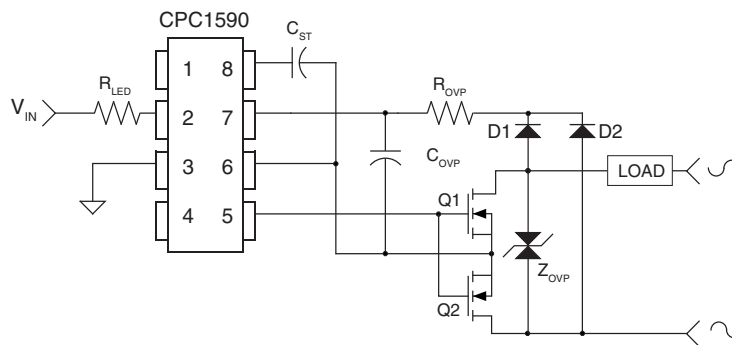

For additional information please visit our website at: [www.clare.com](http://www.clare.com)

Clare, Inc. makes no representations or warranties with respect to the accuracy or completeness of the contents of this publication and reserves the right to make changes to specifications and product descriptions at any time without notice. Neither circuit patent licenses nor indemnity are expressed or implied. Except as set forth in Clare's Standard Terms and Conditions of Sale, Clare, Inc. assumes no liability whatsoever, and disclaims any express or implied warranty, relating to its products including, but not limited to, the implied warranty of merchantability, fitness for a particular purpose, or infringement of any intellectual property right.

The products described in this document are not designed, intended, authorized or warranted for use as components in systems intended for surgical implant into the body, or in other applications intended to support or sustain life, or where malfunction of Clare's product may result in direct physical harm, injury, or death to a person or severe property or environmental damage. Clare, Inc. reserves the right to discontinue or make changes to its products at any time without notice.

Specification: AN-202-R00B  
©Copyright 2009, Clare, Inc.  
All rights reserved. Printed in USA.  
9/10/09