

APPLICATION NOTE AN-123

Using CYG2911 and TS117 in APOH (911) Circuits



CLARE

Someone dial 911!

A modem is on-line and a user must place an emergency “911” call. After picking up the phone and waiting for a dial tone, the user hears the familiar bleeps of a modem device while it is on-line. The modem device could be on an electricity meter, a gas meter or a set-top box; the user does not know which one is in use but it must hang up to allow the user telephone voice priority.

Another Phone off Hook

Another phone off-hook (APOH) or “911” detection circuitry is becoming an important feature that today’s modem or other telephony equipment developer is incorporating into designs. These circuits can be used to allow emergency calls and other prioritized telephone usage over modem devices.

The intent of this application note is to describe two classifications of APOH circuits, and how Clare’s CYG2911 DAA module and TS117 multifunction solid state relay products can be implemented in these applications.

Class 1 - Modem device in use

A modem device is using the telephone line and a user wishes to place an emergency or 911 call as in the scenario described above. When the user’s telephone goes off-hook, the modem device must recognize this and HANG UP; thus allowing the user telephone line privileges so they can place the emergency call.

911

The first circuit is the “911” circuit incorporated in Clare’s DAA module P/N CYG2911. For more information on the CYG2911, refer to the CYG2911 Performance Specifications data sheet. As the 911 circuit used in this device is proprietary to Clare, the only information on the circuit is as follows:

The modem device incorporating the CYG2911 is using the telephone line (data or voice transmission is taking place). When a user takes a phone off-hook to place an emergency call, the CYG2911 will detect this and pulse the 911 pin logic HIGH or approximately 50 milliseconds (mS) as shown in figure 1. The modem firmware must then interpret this signal and hang up the CYG2911. Now the second phone can place the 911 or other emergency call. Keep in mind that when the CYG2911 first seizes the phone line, there may be some glitches present on the 911 pin and these should be ignored for a minimum of 200mS.

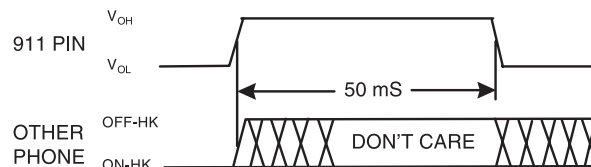

Figure 1 - CYG2911 911 Circuit Timing

Class 2 - Telephone device in use.

A user is on the telephone (or is using the telephone line to transfer information; internet, remote monitoring, etc.) and a modem device wishes to use the line. The modem device should poll the line to see if it is in use. If the line is in use, the modem should stay on-hook and try again later.

APOH

Figure 2 is a circuit showing a possible APOH circuit. Unlike the 911 circuit mentioned above, this circuit can be used to poll the telephone line to see if a call is in progress. This circuit uses Clare’s TS117 telecom switch incorporating a solid state relay (SSR) and opto-coupler in one package.

Circuit Description

When a phone goes off-hook, the central office battery voltage across TIP and RING drops from 48VDC to 4-11VDC depending on loop resistance, distance from the telephone central office, etc. In this situation the user’s CONTROL single is a don’t care; the 30V Zeners, Z1 and Z2, are not conducting and the circuit is open across TIP and RING.

Circuit Description

When a phone goes off-hook, the central office battery voltage across TIP and RING drops from 48VDC to 4-11VDC depending on loop resistance, distance from the telephone central office, etc. In this situation the user's CONTROL signal is a don't care; the 30V Zeners, Z1 and Z2, are not conduction and the circuit is open cross TIP and RING.

The Zeners will only conduct when the voltage across TIP and RING exceeds 30VDC, or when all of the phones n this connection are on-hook. Driving the CONTROL signal logic HIGH will close the normally open (1-Form-A) SSR in the TS117. This places the opto-coupler into the circuit across TIP and RING thus changing the state of the STATUS signal from HIGH to LOW. The STATUS signal can then be processed by the user's firmware.

The CONTROL signal must be able to drive the SED of the SSR a min. of 5mA at 25°C. (Refer to the TS117 Performance Specifications for determining the proper LED current for temperatures > 25°C). If 5mA is not available from the host, the CONTROL signal will need to be buffered using a logic driver, op-amp or small signal transistor.

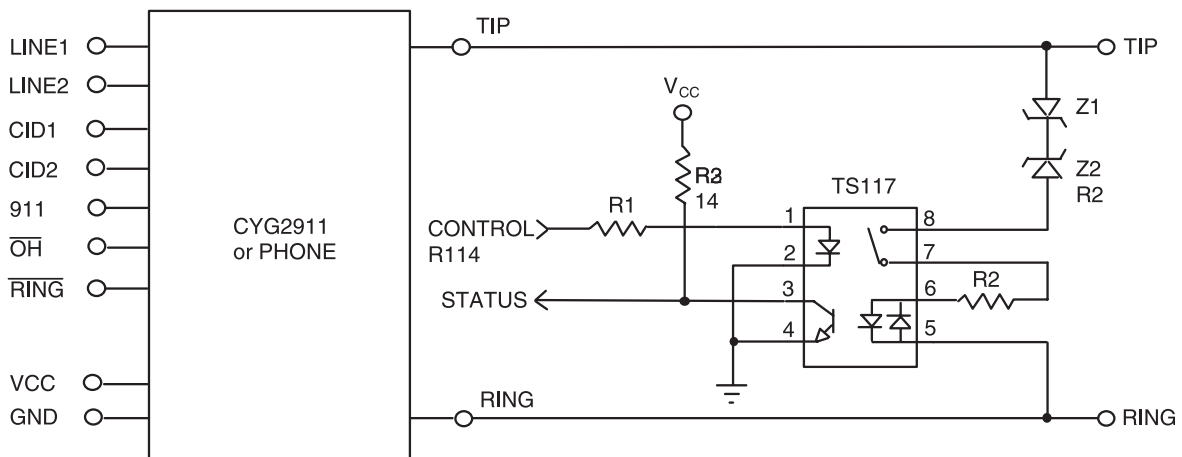

Figure 2. TS117 APOH Circuit

Component Values

R1 - Select R1 to limit the SSR LED current to 5-10mA from the CONTROL signal. For a CONTROL signal of 5V:

$$R1 = (5 - V_{LED}) / 10E - 3 = (5 - 1.4) / 10E - 3$$

$$R1 = 360 \text{ Ohms}$$

R2 - Used to limit the opto-coupler LED current to approximately 1mA across tip and Ring. (The current must be <<20mA otherwise the central office will send a dial tone presuming the system has gone off-hook). For a max. central office battery voltage of 52VDC.

$$R2 = 52 / 1E - 3 \sim 51k \text{ ohms.}$$

R3 - this pull-up should be set so that the min. 33% CTR of the opto-coupler will switch the transistor. (For 1mA LED current, the min. collector current will be 0.33mA). For a V_{CC} of 5V:

$$R3 = (V_{CC} - V_{CESAT}) / IC = (5 - 0.3) / 0.33$$

$$R3 \sim 14k \text{ ohms}$$

Z1, Z2 - These should be rated at 30VDC.

Handling and Assembly Recommendations

The CYG2XXX products are not hermetically sealed and should not be exposed to any liquid-based rinsing processes. Clare recommends two (2) approaches. The modem should either use a no clean soldering flux that would mostly evaporate during the normal wave soldering processes, or be soldered in by hand after the rest of the card is wave soldered.

**Summary**

By using the DAA module P/N CYG2911 and the P/N TS117 APOH circuit described above, both emergency cal conditions can be met. Again, these circuits only indicate a condition; it is up to the systems engineer to design a robust system which can make use of these circuits. This will typically require interface to a microcontroller (through interrupt service routines, etc.) along with the appropriate software drivers.



CLARE

For additional information please visit our website at: www.clare.com

Clare, Inc. makes no representations or warranties with respect to the accuracy or completeness of the contents of this publication and reserves the right to make changes to specifications and product descriptions at any time without notice. Neither circuit patent licenses nor indemnity are expressed or implied. Except as set forth in Clare's Standard Terms and Conditions of Sale, Clare, Inc. assumes no liability whatsoever, and disclaims any express or implied warranty, relating to its products including, but not limited to, the implied warranty of merchantability, fitness for a particular purpose, or infringement of any intellectual property right.

The products described in this document are not designed, intended, authorized or warranted for use as components in systems intended for surgical implant into the body, or in other applications intended to support or sustain life, or where malfunction of Clare's product may result in direct physical harm, injury, or death to a person or severe property or environmental damage. Clare, Inc. reserves the right to discontinue or make changes to its products at any time without notice.

Specification: AN-123-R1.0
©Copyright 2002, Clare, Inc.
All rights reserved. Printed in USA.
6/25/02