

APPLICATION NOTE AN-122

Cybergate™ 21XX Series



CLARE

Clare's Cybergate™ 21XX Series Data Access Arrangement (DAA) Module, the CYG2100 (UK, Australia, New Zealand, Finland, Sweden, Norway, Denmark, Holland, Portugal, Italy, Luxembourg, Austria, Belgium) /CYG2110 (France) /CYG2120 (Spain), combines all of the circuitry necessary to implement a complete telephone line interface solution including:

- Low Distortion Signal Coupling (V.34 compatible)
- 300V Surge Protection
- Mute Relay
- Compatible with EN55022 and EN50082-1
- 1.5KV_{RMS} Isolation
- On/Off Hookswitch Relay
- Certified to EN60950
- Full-Wave Ring Detection

Typical applications for the CYG21XX Series include:

- Home Medical Devices
- Security/Alarm Systems
- Utility Meters
- Vending Machines
- Network Routers
- PC Mother Boards
- Digital Telephone Answering Machines
- Plant Monitoring Equipment
- Modems
- Voicemail Systems
- Elevator Control Boxes
- PBX Systems
- Telephony Applications

Description

The CYG21XX Series DAA Module integrates a complete line interface circuit into a compact 1.07" x 1.07" x 0.4" package. The following is a list of major functions included in the DAA, as shown in the functional diagram in figure 1:

- Hookswitch Circuitry
- Surge Protection
- Transformer Coupling
- Ring Detection Circuitry
- Gyrator Circuitry
- Mute Function

A brief description for each of these functions follows:

Hookswitch Circuitry

The hookswitch asserts the on-hook and off-hook conditions for the phone interface (the difference between being "on-line" and "off-line"). The hookswitch is activated by the host when the host wishes to place a call or answer a call in response to an incoming ring signal. In order to perform this function in the most effective manner, the CYG21XX Series uses a highly reliable solid state relay activated when the \overline{OH} pin on the CYG21XX is driven low (logic '0').

Block Diagram

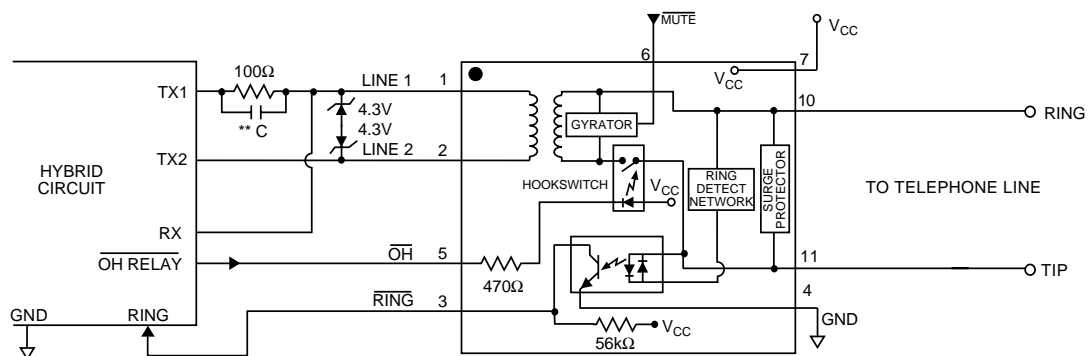

Figure 1

The current required at the input to operate the relay is 8mA minimum over temperature range 0 to +70°C. The solid state relay provides no contact “bounce” and provides up to 350V blocking voltage when on-hook.

Ring Detection Circuitry

The ring detection circuitry detects the ring signal from the central office, which indicates the presence of an incoming call. This ring signal is a high voltage AC signal superimposed on the central office DC battery nominally 48VDC. This AC signal can be at any frequency between 15-60Hz and have an RMS voltage between 25 and 120 volts, with a typical ring cadence of 2 seconds on and 4 seconds off. The ring detection network includes an LED that emits light on one half cycle of the ring frequency and couples this light to an output phototransistor. The output phototransistor provides pulses from +V_{CC} (via an internal 56K pull-up resistor) to ground, in response to the ring signal. These pulses are presented to the RING pin on the CYG21XX Series. The duty cycle of these pulses is dependent on the amplitude and frequency of the incoming ring signal. The RING signal is typically connected to an input port on the microcontroller or data pump located on the host system, where it is qualified as a valid ring signal.

Surge Protection Circuit

Metallic (Tip to Ring) surge protection is another key feature included in the CYG21XX Series. All circuits function per specification under normal conditions.

Gyrator Circuitry

The gyrator circuit included in the Cybergate™ provides a low DC resistance and a high AC impedance to the telephone line when the CYG21XX Series is in the off-hook state. By doing this, the gyrator is approximating the operation of an inductor (a space saving feature as opposed to using a discrete inductor). The electronic inductor circuitry is required so that the DC current from the telephone line is diverted away from the transformer windings, thus providing the high linearity necessary for V.34 modem performance.

Transformer Coupling

A low distortion transformer is used to couple voice/data/fax signals to and from the CYG21XX Series. The transformer provides the galvanic isolation of 1500V_{RMS} required to meet the supplementary level of isolation of EN60950/EN41003.

Mute Function

The Mute function provides a low impedance for pulse dial. During pulse dialing, the MUTE control is activated on or slightly before (no more than 50 ms) the start of the first dial pulse. It is then kept active until or just after the end of the last pulse of the dial string (no more than 50ms again).

Power Consumption

The CYG21XX Series consumes very little power from the host system. This power is mainly limited to the hookswitch relay which consumes about 40mW with a +V_{CC} of 5V and corresponding LED current of 8mA. +V_{CC} can be greater than +5V if desired as there is an internal 470Ω LED current limiting resistor in the CYG21XX Series.

It is important to note that +V_{CC} should be no higher than 20V. This is because the ring detect output transistor's collector is pulled to +V_{CC} via a 56K resistor. The maximum V_{CEO} of the transistor is 20V and should therefore not be exceeded.

The CYG21XX Series is designed to dissipate about 1.5W of power from the telephone line at a maximum ambient temperature of 70°C.

Interfacing the CYG21XX Series to a Modem Chip

Figure 3 shows a CYG21XX Series connected to a Rockwell 224ATF Fax/Data modem. The 224ATF has an internal 2-4 wire hybrid that eliminates the need for an external hybrid circuit. The modem circuit shown is a 2400 bps data modem with 9600 bps fax capability. The TXA1 and TXA2 pins from the 224ATF represent the differentially driven transmit signal and the RXA is the single-ended signal from the telephone line to the

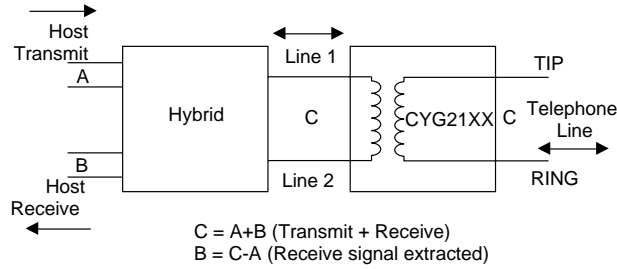

Figure 2
Two-to-Four Wire Hybrid Diagram

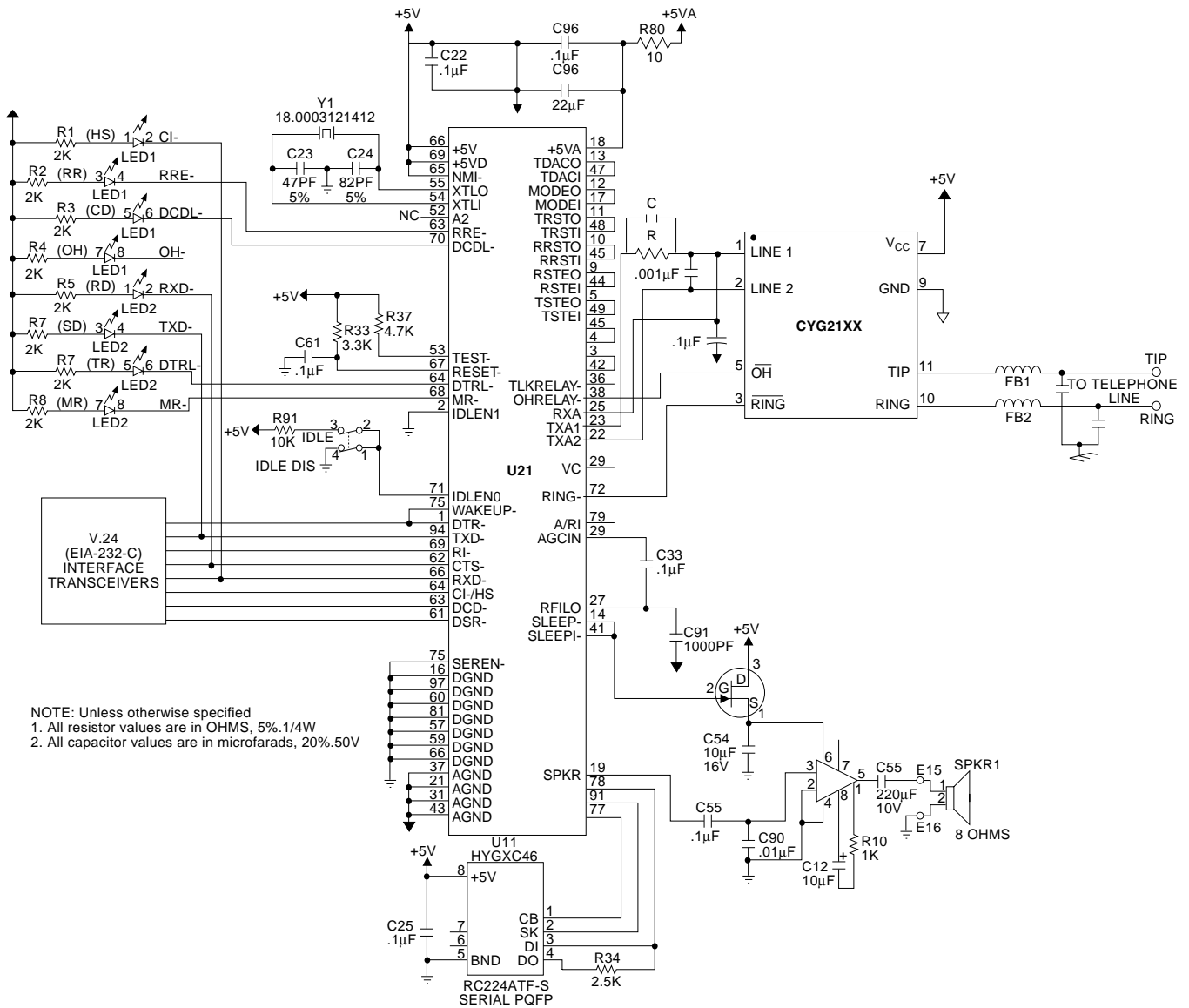

Figure 3
Rockwell 224ATF Fax/Data Modem

Applications Requiring an External 2-4 Wire Hybrid Circuit

For full-duplex communications over the telephone line, it is required that other transmit signals (signals from the host to the telephone line) and receive signals (signals from the telephone line to the host) appear simultaneously in the single pair telephone line. It is the function of the 2-4 wire converter or hybrid to separate the transmit and receive signals from the single pair telephone line and put out the receive signal for the host to process. The hybrid also functions - along with the coupling transformer - to set the proper matching impedance for the telephone line and transmit the host transmit signal to the coupling transformer. It's important to note that most modems today have this hybrid function built into the chip set (refer to figure 3) so it won't be required to design a hybrid circuit in many cases. However, other applications including voice processing circuits may require an "external" hybrid circuit.

Referring to figure 2, the host transmit pair sends a signal denoted as 'A' to the telephone line via the CYG21XX Series. Signal 'C' on LINE1/LINE2 and TIP/RING represents both the transmit signal from the host 'A' and the signal from the telephone line to the host denoted as 'B'. signal 'C' is the sum $A + B$. The hybrid extracts the receive signal from the telephone line by subtracting the transmit signal from the composite signal appearing at C or $B = C - A$.

The practical implementation of the above scheme varies depending on the particular application, however, we will examine a very basic hybrid circuit as an example. The hybrid circuit usually consists of a dual operational amplifier and some discrete resistors as shown in figure 4. To simplify the analysis of the circuit we will explain the operation of:

- Transmit to the telephone line
- Receive from the telephone line
- Cancellation of the host transmit signal VT from the receive path VR

Transmit to the Telephone Line

Suppose that the VT signal from the host system is at a level of -9dBm and we wish to have this signal presented to the telephone line at this level. Since the transmit insertion loss from the data sheet is specified at 7dB, it is necessary to select resistor values R2 and R1 such that U1A will amplify VT by 7dB. Since gain (dB) = $20 \text{ Log } [R2/R1]$ we select an arbitrary value of R2 and then calculate R1. For this example we select R2 = 20K which yields an R1 of approximately 9.1K.

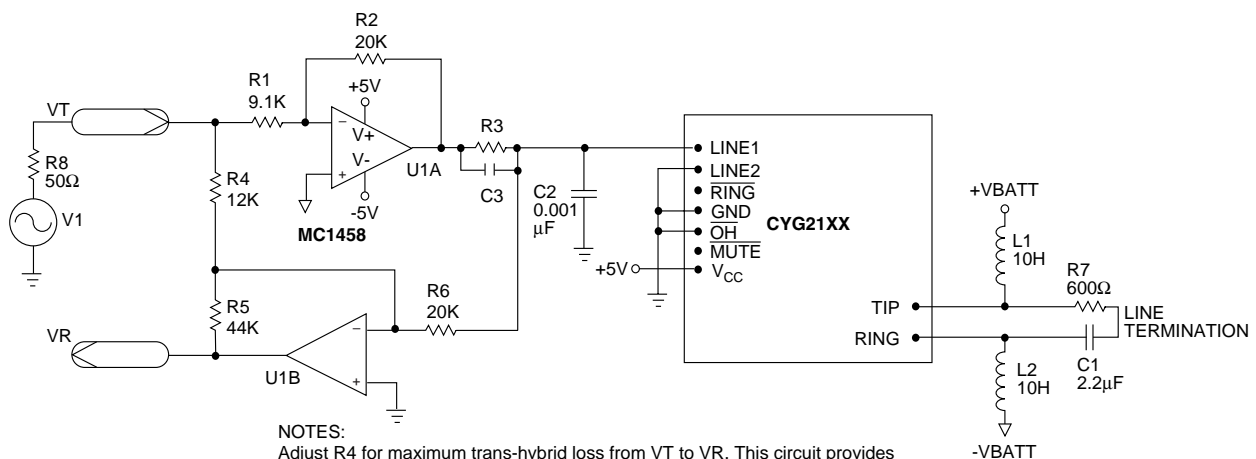

NOTES:
Adjust R4 for maximum trans-hybrid loss from VT to VR. This circuit provides approximately -20dB loss.

R2/R1 provides +7dB amplification to compensate for -7dB transmit insertion loss in circuit.

R5/R6 provides +7dB amplification to compensate for -7dB receive insertion loss in circuit.

R3/C3 provides optimum return loss for nominal 600Ω line termination.

Figure 4
Hybrid Circuit

Receive from the Telephone Line

In a similar manner to the transmit calculation, we obtain the receive insertion loss from the performance specifications and note that it is approximately 7dB. For an overall DAA gain of 1, it is necessary to select resistor values R5 and R6 such that 7dB amplification is achieved. Assuming R6 is 20K, R5 is calculated to be 44K.

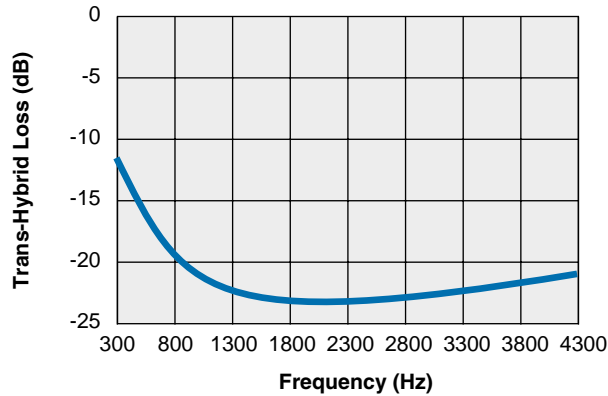
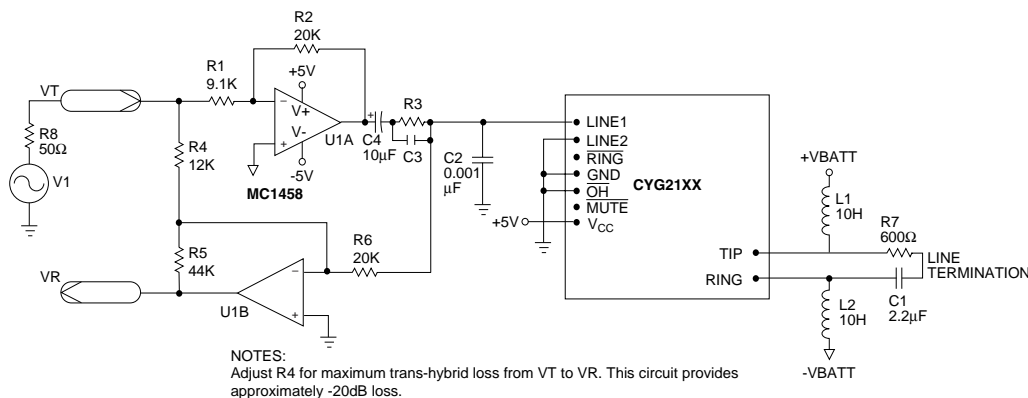

Figure 5
CYG21XX Series Trans-Hybrid Loss

Receive and Transmit Signal Separation - Trans-hybrid loss

We now have the transmit and receive gains of U1A and U1B set such that VR will be at the same signal level as the incoming receive signal appearing on the Tip and Ring connections. Also, the Tip and Ring connections will see the same level transmit signal as VT. We must now attenuate the signal transmitted by the host system at VT to keep it from entering the receive path at VR, thus providing receive and transmit separation and completing the 2-4 wire converter. U1B is configured as a summing amplifier that sums the transmit VT signal with the transmit signal appearing at the LINE1 input of the CYG21XX Series. These signals are 180° out of phase, therefore the resultant output of U1B will be 0V, thus removing the trans-hybrid loss. In practical circuits, it is not possible to achieve infinite loss. Losses can range from -10dB to -40dB depending on how well the components are matched and the impedance of the telephone line. Since the telephone line is a complex impedance, trans hybrid loss also varies over the 300Hz - 4kHz voice band as shown in figure 5. R4 should be optimized to achieve the highest trans-hybrid loss possible with terminations shown in figure 6. R7 and C1 comprise a network to emulate the typical telephone line impedance.

Telephone line character varies from location to location in actual applications. Referring to figure 7, the return loss maxima occur at the center of the voice band which is desirable for optimum operation.



NOTES:
Adjust R4 for maximum trans-hybrid loss from VT to VR. This circuit provides approximately -20dB loss.

R2/R1 provides +7dB amplification to compensate for -7dB transmit insertion loss in circuit.

R5/R6 provides +7dB amplification to compensate for -7dB receive insertion loss in circuit.

R3/C3 provides optimum return loss for nominal 600Ω line termination.

Figure 6
CYG21XX Series Hybrid Circuit with DC Blocking Capacitor (C4)

Precautions When Implementing the Hybrid Circuit

Due to the small size and low distortion characteristics of the CYG's transformer, it is extremely important to use op amps with a low DC output offset voltage. Generally, any DC voltage exceeding 10mV on the output of U1A can cause the transformer's distortion characteristics to degrade due to core saturation. For op amps with higher output offset, it is advisable to use a 10µF capacitor (aluminum or tantalum) in series with R3 as shown in figure 6. This capacitor will block any DC offset voltage thus maintaining the transformer secondary DC current at 0mA. Op amps such as the MC1458 were found not to require this capacitor due to their offset being sufficiently low. The voltage rating of the capacitor should be rated 50VDC.

Return Loss Performance

The return loss is the measure of impedance mismatch of the telephone line and the DAA expressed in dB. Return loss is expressed as:

$$RL(dB) = 20 \text{ Log } \frac{[Z_L + Z_O]}{[Z_L - Z_O]}$$

Z_L = Telephone line impedance in Ω

Z_O = DAA impedance in Ω

If $Z_L = Z_O$ then the return loss is infinity which is the ideal case. As in the trans-hybrid loss case however, practical return loss figures are much lower than infinity and more like -25dB. Since impedance changes with frequency, the return loss also changes. A graph of return loss vs. frequency for the CYG21XX Series is shown in figure 7. This graph was generated with the CYG21XX Series terminated by a 600 Ω + 2.16µF combination across Tip and Ring connections. Referring to figure 6, the key component determining the return loss match is the resistor (R3) and capacitor (C3) feeding the Cybergate™ transformer secondary. This resistor value was selected for optimum return loss when used with the CYG21XX Series and should not deviate in value by more than 5%. The value of R3 can vary from 100 Ω up to 900 Ω depending on the country.

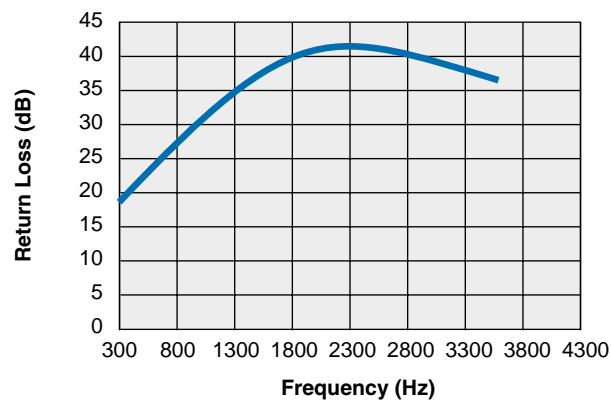

Figure 7
CYG21XX Series Return Loss

Frequency Response

The CYG's frequency response is fairly flat with a deviation of ± 0.2 dB. Its frequency response is shown in figure 8.

Regulatory Considerations

Interface to the Public Switched Telephone Network (PSTN)

The CYG21XX Series has been designed to comply with PTT clauses relevant to DAA specifications from the following standards:

It is required however, that the designer submit the end product to a test lab to receive certification from the appropriate regulatory agency.



AN-122

Country	Relevant Specification
UK	NV NTR
Australia	TS002
New Zealand	PTC102, PTC211
Finland	ETS 300 001/SP-Method 1732
Sweden	SS-ETS 300-001 T3
Norway	GFA/SP-AR 1990-61
Denmark	ETS 300-001 NET4
Holland	T10-00, T11 Series
Portugal	ICP 25.01.51.001
Spain (CYG2120)	UNE-ETS 133 001 (Parts1&2)
Italy	ETS 300-001 NET4
Luxembourg	Holland Specs
Australia	FTV221,FTB201,FTV310
Belguim	BE/SP-201 (NET4)
France (CYG2110)	B1123A

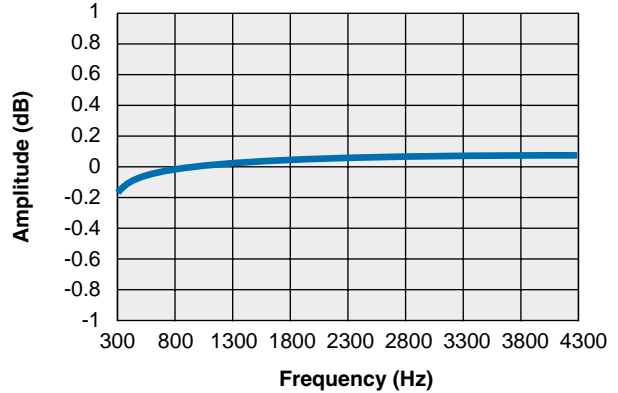

Figure 8
CYG21XX Series Frequency Response

EMI Considerations

The CYG21XX Series is designed to meet both EN55022 and EN50082-1 requirements.

High speed modems and other circuits that contain high frequency crystal oscillator can present special problems when it comes time to submit the device to the compliance lab. In order to minimize the risks associated with radiated emissions, the designer should keep the following points in mind:

- If possible, use a four-layer PCB design instead of a double-sided PCB. Having a separate VCC and ground plane will minimize radiated emissions and decrease the noise susceptibility of the device. An alternative is to do a double-sided board and four layer board in parallel and evaluate the results.
- Include a provision on your PCB design for a 1/2 turn ferrite bead and capacitor in your layout from the Tip and Ring terminals of the DAA to the telephone jack as shown in figure 9. This LC network will form a low pass filter that will roll off high frequencies. The decision to populate the board with these components will be based on the results of the radiated emissions coming out of the telephone line during EMI testing.
- If a multi-layer board is not used, keep ground traces at least 25 mils to 50 mils wide.
- Maintain LINE1 and LINE2 connections as short as possible and use guarding techniques when running these traces.
- Maintain Tip and Ring connections at least 100 mils away from all other connections on the boards. If a ground plane is used, keep the plane away from Tip and Ring connection.

Conclusions

The Cybergate™ 21XX Series is a complete, functional Data Access Arrangement (DAA), and complements Clare’s complete line of integrated telecommunication solutions. By incorporating all of our core technologies, such as solid state switching, optical coupling and transformer/coil technology, we are able to provide an unmatched level of functionality and integration for the telecom interface design. Technically, the CYG21XX Series includes the surge protection, ring detection, mute function, hookswitch circuitry, and impedance balancing circuits required for the interface design in a compact 1.07” x 1.07” x0.4” module. In all, advantages are numerous when utilizing this complete drop-in DAA solutions.

Some of the more obvious benefits are as follows:

- Plug and Play DAA
- Reduced design costs
- Very low risk design solution
- Compact design for space/PCB cost savings
- Reduced “design to market” time
- Complete integrated solution, including surge protection and transformer

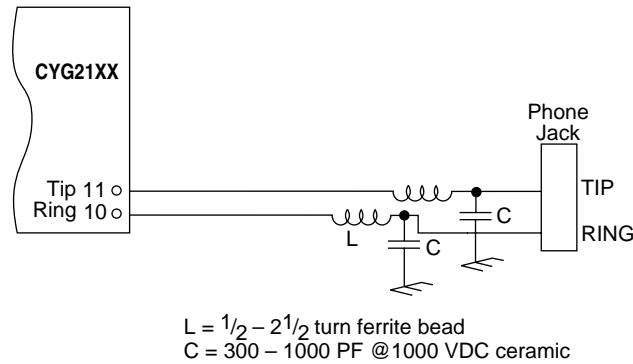

Figure 9
EMI Considerations

Matching Resistor Effect on Insertion Loss

Table 1 provides some recommended matching resistor values (R_M) for various countries when using the CYG21XX series. Note that with a 350Ω resistor the transmit and receive insertion losses are approximately -7dB maximum as stated in the data sheet when measured against the network impedance on Tip and Ring. This value has been determined to give optimum return loss performance in the United Kingdom, Ireland, and Iceland.

For other countries, a range of values from 100Ω to 270Ω are listed for R_M . Tradeoffs with return loss and receive insertion loss are associated with selecting a resistor value within this range. Figure 1 shows the relationship graphically. Note that when using a 100Ω resistor, maximum return loss is achieved while increasing receive insertion loss. When a value of 270Ω is used, receive insertion loss is minimized as well as return loss. Most countries require a minimum return loss value of 14dB. Based on this information, the designer can choose a compromise value. Final values for the matching resistor will ultimately be determined during PTT testing of the customer's end product where PTT requirements and performance requirements are optimized. receive insertion losses can be compensated for by increasing receive gain in the hybrid circuit.

Cybergate Model #	Country	Network or 600Ω Used	Matching Resistor, R_M
2100	Austria	600Ω	100Ω-270Ω
23xx	Australia	TBD	TBD
2100	Belgium	600Ω	100Ω-270Ω
2100	Cyprus	600Ω	100Ω-270Ω
2100	Denmark	600Ω	100Ω-270Ω
2100	Finland	600Ω	100Ω-270Ω
2110	France	600Ω	100Ω-270Ω
2300	Germany	Network	560Ω-620Ω
2100	Greece	600Ω	100Ω-270Ω
2100	Iceland	Network	350Ω
2100	Ireland	Network	350Ω
2100	Italy	600Ω	100Ω-270Ω
2100	Luxembourg	600Ω	100Ω-270Ω
2100	Malta	600Ω	100Ω-270Ω
2100	Netherlands	600Ω	100Ω-270Ω
2100	Norway	600Ω	100Ω-270Ω
2100	Portugal	600Ω	100Ω-270Ω
2120	Spain	600Ω	100Ω-270Ω
2100	Sweden	600Ω	100Ω-270Ω
23XX	Switzerland	TBD	TBD
2100	United Kingdom	Network	350Ω

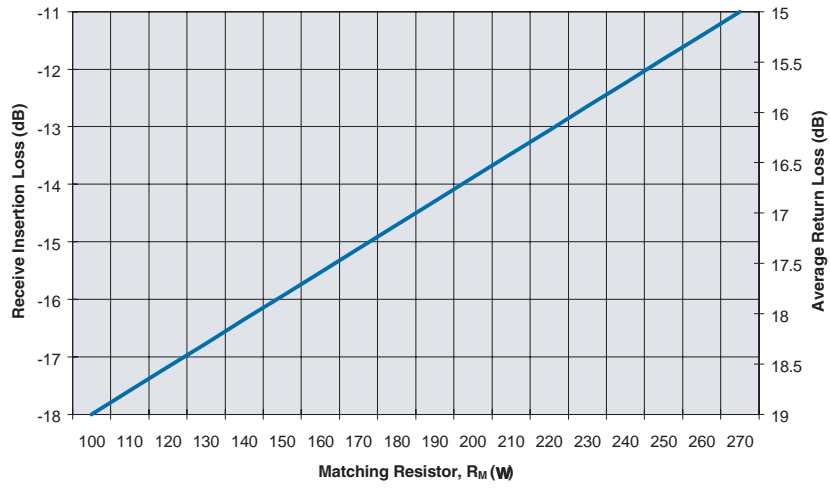

Figure 10
Receive Insertion Loss/Average Return Loss vs. Matching Resistor (R_M)



CLARE

For additional information please visit our website at: www.clare.com

Clare, Inc. makes no representations or warranties with respect to the accuracy or completeness of the contents of this publication and reserves the right to make changes to specifications and product descriptions at any time without notice. Neither circuit patent licenses nor indemnity are expressed or implied. Except as set forth in Clare's Standard Terms and Conditions of Sale, Clare, Inc. assumes no liability whatsoever, and disclaims any express or implied warranty, relating to its products including, but not limited to, the implied warranty of merchantability, fitness for a particular purpose, or infringement of any intellectual property right.

The products described in this document are not designed, intended, authorized or warranted for use as components in systems intended for surgical implant into the body, or in other applications intended to support or sustain life, or where malfunction of Clare's product may result in direct physical harm, injury, or death to a person or severe property or environmental damage. Clare, Inc. reserves the right to discontinue or make changes to its products at any time without notice.

Specification: AN-122-R1.0
©Copyright 2002, Clare, Inc.
All rights reserved. Printed in USA.
6/25/02